

FALL RIVER COUNTY UNAPPROVED MINUTES OF OCTOBER 15, 2019

The Fall River Board of County Commissioners met in regular session on October 15, 2019. Present: Joe Falkenburg, Paul Nabholz, Deb Russell and Sue Ganje, Auditor. Ann Abbott and Joe Allen were absent.

The Pledge of Allegiance was given, and the meeting called to order at 9:00 a.m.

The agenda was reviewed for conflicts; none were noted. ALL MOTIONS RECORDED IN THESE MINUTES WERE PASSED BY UNANIMOUS VOTE, UNLESS OTHERWISE STATED. The full context of the meeting can be found on the county website under Commissioners at <http://fallriver.sdcounties.org>, or, You Tube under Fall River County Commission SD.

Motion made by Russell approve the agenda, as written. Nabholz asked to add to the agenda a motion to rescind the \$1,500.00 action on October 1, 2019 to fix Battle Mountain Road. Russell approved the amended agenda, Nabholz seconded, motion carried.

Motion made by Nabholz, seconded by Russell, to approve the minutes of October 1, 2019.

Motion made by Nabholz, seconded by Russell, to approve the Auditor's Account with the Treasurer as follows:

AUDITOR'S ACCOUNT WITH THE COUNTY TREASURER

TO THE HONORABLE BOARD OF COUNTY COMMISSIONERS OF FALL RIVER COUNTY:

I hereby submit the following report of my examination of the cash and cash items in the hands of the County Treasurer of this County on this 30th day of September 2019.

Total Amt of Deposit in First Interstate Bank: \$434,281.00

Total Amt of Deposit in First National Bank of Lead: \$1,000.00

Total Amount of Cash: \$1,618.97

Total Amount of Treasurer's Change Fund: \$900.00

Total Amount of Checks in Treasurer's

Possession Not Exceeding Three Days: \$33,492.78

SAVINGS:

First Interstate Bank: \$461,532.04

First National Bank of Lead: \$1,031,960.42

CERTIFICATES OF DEPOSIT:

First Interstate-Hot Springs:	<u>\$4,056,787.49</u>
Black Hills Federal Credit Union:	<u>\$250,000.00</u>
Bank of the West	<u>\$525,542.47</u>
Schwab Treasury	<u>\$1,300,000.00</u>

Itemized list of all items, checks and drafts that have been in the Treasurer's possession over three days:

Register of Deeds Change Fund: \$500.00
Highway Petty Cash: \$20.00
Election Petty Cash: \$15.00

RETURNED CHECKS:

Bayan, Fritchie \$957.52, Lic 08/24/2018
Richardson, Brent \$356.80, Lic 09/13/2019

TOTAL \$8,098,964.49

Dated This 30th Day of September 2019.

/s/ Sue Ganje, County Auditor of Fall River County

County Monies: \$7,619,713.35
Held for other Entities: \$310,124.50
Held in Trust: \$169,126.64
TOTAL: \$8,098,964.49

The Above Balance Reflects County Monies, Monies Held in Trust, and Monies Collected for and to be remitted to Other ENTITIES: SCHOOLS, TOWNS, TOWNSHIPS, FIRE, AMBULANCE AND ROAD DISTRICTS, AND THE STATE.

The board reviewed a letter from US Board on Geographic Names in response to the request to change the name of Larvie Lake to Hidden Lake; this was not an approved change.

There were no county assistance or death expense applications.

Motion made by Nabholz, seconded by Russell, to rescind the motion to pay \$1,500 for the county share of maintenance on Battle Mountain Road as it was not on the October 1, 2019 agenda. This will be on the November 5, 2019 agenda.

Frank Maynard, Emergency Management, met with the board. Motion made by Russell, seconded by Nabholz, to approve the 4th quarter SLA agreement and authorize the chairman to sign.

Discussion was held on emergency closings of the courthouse; trainings Maynard attended, and certificates received; quarterly LEPC meeting and grant application, and fires and incidents.

Bob Evans, Sheriff, met with the board. Russell moved to approve the prisoner housing

agreement with Pennington County, and then amended the motion to be contingent on the state's attorney's review. Nabholz seconded the amended motion.

Motion made by Nabholz, seconded by Russell, to approve the pay raise for Sydney Belt, Dispatcher, from \$12.00 per hour to \$12.50 per hour to reflect becoming certified. This to be effective October 4, 2019, as per union contract.

Evans updated the board that there are 15 male and 6 female inmates in Fall River County, with 1 male and 1 female being housed in Pennington County.

Lyle Jensen, Building Supervisor, met with the board. Propane quotes were presented as follows:

9/30/2019 Propane Quotes	10,000-Gal Propane
Nelson's Oil & Gas	\$1.09/gallon
PJ's Hi-D-Way	\$0.80/gallon
Dakota Propane	\$0.899/gallon
CBH Coop	No Bid

Motion made by Russell, seconded by Nabholz, to accept the low bid from PJ's Hi-D-Way in the amount of \$0.80 per gallon, for 10,000 gallons of propane, for a total amount of \$8,000.00.

Motion made by Nabholz, seconded by Russell, to approve four 10-hour days for Dave Weishaupl.

Motion made by Russell, seconded by Nabholz, to allow flex time for Jensen for emergency callouts.

Melody Engebretson, Register of Deeds, met with the board. Motion made by Nabholz, seconded by Russell, to approve hiring Lori Lunzman at \$12.00 per hour as administrative assistant. Effective October 15, 2019, as per union contract, to replace Becky Wendland.

A 5-minute break was taken at 9:25 a.m.

The supplement and contingency hearings were held as advertised. Motion made by Russell, seconded by Nabholz, to approve the following resolution:

FALL RIVER COUNTY RESOLUTION #2019-36
Supplemental Budget 2019, #3
Contingency Transfers 2019, #3

WHEREAS, SDCL 7-21-22 provides that the Board of County Commissioners may adopt a supplemental budget, and whereas, as due and legal notice has been given, the following Supplements to expenses for October 15, 2019 be approved as follows to the following departments: Weed Fund 10100X4260615 Weed Supplies, \$9,000.00, Means of finance to be cash from chemical sales, and

WHEREAS, SDCL 7-21-32.2 provides that the Board of County Commissioners may adopt a transfer appropriation from the contingency budget to other appropriations, which are insufficient, a contingency transfer shall be approved and adopted to the following Departments: Juvenile Care 10100X4272215, \$8,060.00; Mental Illness Board 10100X4221445, \$1,325.00

NOW THEREFORE BE IT RESOLVED by the Board of County Commissioners to adopt the Supplemental Budget, #3 and Contingency Transfer #3 for 2019.

Dated at Fall River County, South Dakota this 15th day of October 2019.

ATTEST:

/s/Sue Ganje

Fall River County Auditor's Office

/s/Joe Falkenburg

Fall River County Board of Commissioners

The hearing for the Malt Beverage & SD Wine and Wine & Cider licenses was held as advertised. Motion made by Russell, seconded by Nabholz, to approve the 2019 – 2020 malt beverage & SD wine and 2019 Wine & Cider licenses for Dollar General in Edgemont.

Doug Kinniburgh, Engineering Supervisor, SD DOT met with the board to give updates on State road projects in Fall River County. Falkenburg asked the audience to be respectful and allow others to speak. Discussion began with Murdock's request for a copy of the agreements when Old HWY 79 and Old HWY 18 were transferred to the county; the tentative bid letting on March 18, 2020 for the Chilson bridge, and that there should be no hold up on the project due to the possible historical site.

Discussion was also held on a portion of the road from Gull Hill where there is no shoulder, the county will be using rock and rip rap to build it back up this week. Discussion was also held on the jake brake ordinance.

Discussion was held on the Igloo/Provo project. The final plans are in review and will be released for right-of-way negotiations this winter. This project is scheduled for bid in the fall of 2020. Ownership of the bridge was discussed. The Burdock Bridge was also discussed with a 2020 bid letting with completion in 2021. Rough figures for costs were given for each project.

Randy Seiler, Highway Superintendent, met with the board. Motion made by Nabholz, seconded by Russell, to approve the September 2019 fuel used or work performed to reimburse the highway department as follows: Sheriff's Department for \$2,892.75; Weed and Pest Office for \$156.50; Building for \$61.70; Emergency Management for \$112.83; Director of Equalization for \$177.23; Auditor for \$5.51; VSO for \$10.35; and Treasurer for \$5.51.

Seiler discussed the possible purchase of a new v-plow when they purchase the new road grader and is looking at a skid loader. Seiler will bring back more costs for this. The highway department will be pouring concrete under the Ardmore Bridge. When the culverts get here, it will take two days to complete the project. Discussion was also held on gravel, minimum maintenance roads, the west four miles out of Oelrichs on Old Hwy 79 and ownership of the bridge by Igloo.

Motion made by Nabholz, seconded by Russell, to move the approval for bills, break and

public comment to after the 5-year plan hearing.

The 5-year plan hearing was held as advertised. Seiler explained the projects on the plan. Challenges were faced this year with unusual wet weather. Seiler will find out if the Community grant was approved for the streets in Oelrichs. Because of the damage and reconstruction of the Ardmore Bridge with culverts, it is no longer considered a bridge; Seiler is hopeful that FEMA will assist with some of the costs. Discussion was also held on the Bridge Improvement Grants, and how larger counties are increasing their share to qualify for bridges. \$200,000 - \$300,000 is the estimated cost of the Ardmore Bridge. Nabholz noted dislike of the plan as incorrect numbers are used for costs, etc. The 5-year plan is a work in progress. The road to the lake was briefly discussed, Seiler noted it is in for a future year to be chip sealed. Questions were asked about Old Hwy 18 not being included on the plan; this will be maintained as needed by the county and is in the normal rotations for road work.

Motion made by Russell, seconded by Nabholz to approve the 5-year plan.

Break was taken at 10:39 a.m. and the meeting reconvened at 10:47 a.m.

Motion made by Russell, seconded by Nabholz, to approve the bills as follows:

GENERAL FUND

AUDRA HILL CONSULTING,INC	MI QMHP EVALUATION	\$2,081.39
A-Z SHREDDING INC	SHREDDING	\$83.20
BEESEY LAW OFFICE	MI	\$312.00
BEHAVIOR MANAGEMENT	MI	\$400.00
BLACK HILLS CHEMICAL	SUPPLY	\$278.72
BLACK HILLS POWERSPORTS	SERVICE	\$477.72
BUILDER'S FIRST SOURCE	SUPPLY	\$42.98
CASS COUNTY SHERIFF	TAX DEED SERVED	\$57.00
CENTURY BUSINESS LEASING	COPIER LEASE & METER	\$216.80
CLINICAL LABORATORY OF	AUTOPSY	\$417.00
DAKOTA COUNTY SHERIFF	TAX DEED SERVED	\$70.00
EN-TECH LLC	FUMIGATION	\$110.00
DUDE SOLUTIONS	GIS SUPPORT CONTRACT	\$253.31
FALKENBURG, JOE	MILEAGE REIMBURSEMENT	\$174.72
FARRELL,FARRELL &GINSBACH	CAAF	\$3,508.72
GOLDEN WEST TECHNOLOGIES	IT SUPPORT/CONTRACT	\$6,456.12
GOVERNOR'S INN	HOTEL FOR CONFERENCE	\$426.00
HILLS EDGE AUTO SALES	SERVICE	\$66.90
HOT SPRINGS ACE HARDWARE	SUPPLY	\$407.20
LYNN'S DAKOTAMART	SUPPLY	\$75.56
LYNN'S DAK. MART PHARMACY	INMATE PHARMACY	\$359.29
MARCO	COPIER LEASE	\$165.00
MCGLUMPHY, ERIN	TRAVEL REIMBURSEMENT	\$224.19
O'NEILL, JUSTIN	CAAF	\$296.78

PENN CO STS ATTNY OFFICE	MI	\$215.00
PENNINGTON COUNTY JAIL	INMATE HOUSING PENNINGTON	\$4,640.00
PENNINGTON COUNTY SHERIFF	TAX DEED SERVED	\$55.16
PENNINGTON COUNTY	DETOX	\$226.00
POLK COUNTY SHERIFF	TAX DEED SERVED	\$40.00
QUILL CORPORATION	SUPPLIES	\$237.51
RAKNESS, ELIZABETH	TRAVEL REIMBURSEMENT	\$125.00
RAPID CITY JOURNAL (THE)	PUBLICATION	\$797.60
RUSHMORE COMMUNICATIONS	EMERGENCY RADIO REPAIR	\$294.00
SD DEPARTMENT OF HEALTH	BLOOD DRAWS	\$120.00
SERVALL	RUGS AND MATS SERVICE	\$377.31
SHERIDAN COUNTY	TAX DEED SERVED	\$50.00
SONNY'S SUPER FOODS	INMATE SUPPLY	\$47.52
STEVEN'S AUTOMOTIVE	NEW TIRES	\$768.80
TULSA COUNTY SHERIFF	TAX DEED SERVED	\$100.00
WESTERN SD JUV SERV CTR	JUVENILE CENTER	\$6,760.00
BEHRENS, DONNA	TRAVEL REIMBURSEMENT	\$807.03
WITNESS	WITNESS FEE & MILEAGE	\$1,934.28
	TOTAL FOR GENERAL FUND	\$34,555.81
COUNTY ROAD & BRIDGE		
BARKER CONCRETE & CONST	RIP RAP	\$17,121.40
HOT SPRINGS AUTOMOTIVE	SUPPLIES	\$1,159.76
NELSONS OIL & GAS INC.	FUEL	\$17,530.96
	TOTAL FOR COUNTY ROAD AND BRIDGE	\$35,812.12
911 SURCHARGE REIMBURSEMENT		
CENTURY LINK	911 DISTPATCH LINES	\$602.80
	TOTAL FOR 911 SURCHARGE REIMBURSEMENT	\$602.80
EMERGENCY MANAGEMENT		
GOLDEN WEST TECHNOLOGIES	IT SUPPORT/CONTRACT	\$8.50
MARCO	COPIER LEASE	\$34.05
	TOTAL FOR EMERGENCY MANAGEMENT	\$42.55
	TOTAL PAID BETWEEN 10/2/19 AND 10/15/19	\$71,013.30

Public comment was heard from Paul Nabholz, Joe Falkenburg, and Brian Ahrendt. Nabholz had concerns about not being put on the agenda to discuss the conceal carry policy and discuss the state's attorney's determination of that policy. Discussion was held between Nabholz, Falkenburg and Ahrendt on proper procedures and moving forward. Other discussion was held on costs at area landfills.

Stacey Martin, GIS, met with the board. Motion made by Russell, seconded by Nabholz, to authorize the purchase of additional road address markers in the estimated amount of \$1,800.00, but stay within the remaining budget.

Brian Ahrendt, State's Attorney, met with the board to advise on codified laws on a full-time state's attorney, and discussion was held.

Motion made by Nabholz, seconded by Russell, to enter executive session as per SDCL 1-25-2 (1) and SDCL 1-25-2 (3) for personnel and legal purposes at 11:15 a.m. There are no action items when the board comes out of executive session other than to adjourn.

The board came out of executive session at 11:23 a.m.

Motion made by Russell, seconded by Nabholz, to adjourn at 11:24 a.m.

/s/ Joe Falkenburg
Joe Falkenburg, Chairman
Board of Fall River County Commissioners

ATTEST:

/s/ Sue Ganje
Sue Ganje, Fall River County Auditor

REPLY TO:

ALAN I. SALTMAN
ATTORNEY AT LAW
aisaltman@smithcurrie.com

October 20, 2019

Sue Ganje, County Auditor
906 N. River Street
Hot Springs, South Dakota 57747

Re: *Kane County, Utah v. United States* – Class Action Lawsuit
Check in full payment of net share of Judgment for 2015 – 2017 PILT
Underpayments

Ms. Ganje:

Enclosed is a check payable to Fall River County, South Dakota in the sum of \$18,627. That is the County's total PILT underpayment in FYs 2015 – 2017 less the pro rata share of attorney fees and reimbursable expenses awarded by the Court.

Here is how the payment amount was calculated:

1. The attorney fees (\$5,740,607.00) and out-of-pocket litigation expenses (\$26,936.96) awarded by the Court total \$5,767,543.96.
2. Subtracting that total of fees and expenses (\$5,767,543.96) from the total underpayments recovered (\$17,221,821.00) leaves a net recovery of \$11,454,277.04.
3. Dividing the net recovery (\$11,454,277.04) by the total recovery (before deduction of fees and expenses) (\$17,221,821) = 0.665102549 (i.e., 66.5102549%).
4. Your total underpayment of \$28,005 multiplied by 0.665102549 (with result rounded up to next full dollar) = \$18,627.

October 20, 2019

Page 2

Links to the Judgments showing the underpayment amounts for all class members, and the Order awarding attorney fees and reimbursable expenses to be paid to Smith, Currie & Hancock LLP and deducted from the total recovery before distribution to class members, are posted here:

<https://www.smithcurrie.com/PILTPaymentsInfo/>

Our delivery of the enclosed check concludes Smith, Currie & Hancock LLP's representation of Fall River County, South Dakota in this matter.

Sincerely yours,

SMITH, CURRIE & HANCOCK LLP

A handwritten signature in black ink, appearing to read "Alan Saltman", with a long horizontal flourish extending to the right.

Alan I. Saltman

Enclosure

VA

U.S. Department of Veterans Affairs
Veterans Health Administration
Black Hills Health Care System

FORT MEADE MEDICAL CENTER

113 Comanche Road, Fort Meade, SD 57741-1099

HOT SPRINGS MEDICAL CENTER

500 North 5th Street, Hot Springs, SD 57747-1497

October 21, 2019

Fall River County Commission
906 N. River St.
Hot Springs, SD 57747

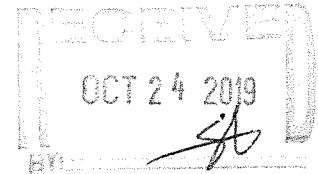

Dear Commissioners:

As our stakeholder and valued partner in Veteran care, I am writing to explain an upcoming change to Urgent Care hours of operation on the Hot Springs campus. Effective November 4, 2019, the hours of Urgent Care will be 7:00 a.m. to 7:00 p.m. Monday through Friday. Urgent Care will follow the same schedule as Primary Care and close on Federal holidays. This change does not indicate a discontinuance of a benefit or service to Veterans receiving care at the Hot Springs campus.

The need to change hours of operation is the result of ongoing staffing shortages. Over the past several years, despite aggressive recruitment efforts and incentive offers, we have been unable to stabilize our provider and nursing workforce in Urgent Care. We are not alone; other rural VA health care systems and community hospitals experience similar challenges attracting talented providers who are committed to practice in small communities. Because of the challenge of recruitment and retention of qualified providers, nurses, and supportive services, such as lab and radiology services, the difficult decision was made to reduce hours. The Urgent Care clinic will continue to provide Veterans the highest level of care and make the best use of available community resources under the MISSION Act 2018.

Veterans may continue to use all the benefits they are eligible to receive through our Call Center for health-related questions and triage at 1-877-339-6837, MyhealthVet secure messaging, and same day access in Primary Care and Mental Health. During a medical emergency, Veterans should seek immediate medical attention without delay. Veterans and eligible family members should seek the closest available emergency care in life-threatening situations regardless of Urgent Care clinic hours of operation.

Veterans do not need to check with VA before calling an ambulance or going to a community Emergency Department. A claim for emergency care won't be denied based solely on VA not receiving notification prior to seeking care. A list of network Urgent Care facilities for eligible Veterans is found at <https://vaurgentcarelocator.triwest.com/Locator/Care>

It is important for Veterans to promptly notify VA after receiving emergency care at a community Emergency Department. Notification should be made within 72 hours of admission to a community medical facility. This allows VA to assist in coordinating necessary care or transfer to VA. It also helps to ensure the administrative and clinical requirements for VA to pay for the care are met. Veterans or a family member may call VA Black Hills Health Care System for Emergency Room notification at 605-745-2000. Information outlining Veteran rights and responsibilities for use of Emergency Medical

care can be found at

https://www.va.gov/COMMUNITYCARE/docs/pubfiles/factsheets/FactSheet_20-02.pdf#.

At VA Black Hills we are committed to providing Veterans with the high quality, safe health care they deserve. Thank you for your continued partnership providing Veterans with the care and benefits they have earned.

Sincerely,

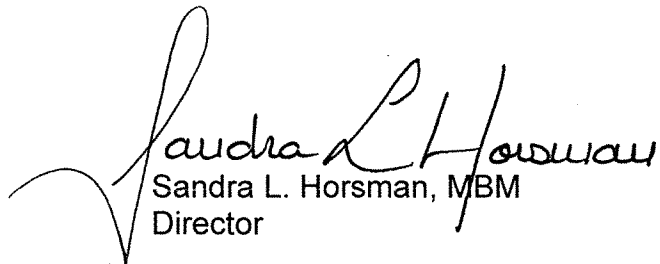

Sandra L. Horsman, MBM
Director

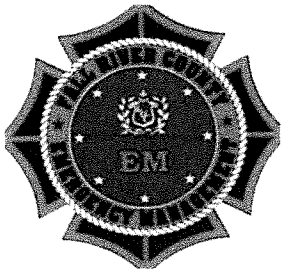

*Emergency Management
Fall River County*

*Franklin W. Maynard CEM CFM
906 N. River St.
Hot Springs, SD 57747*

605 745-7562 605 890-7245 frem@qwtc.net

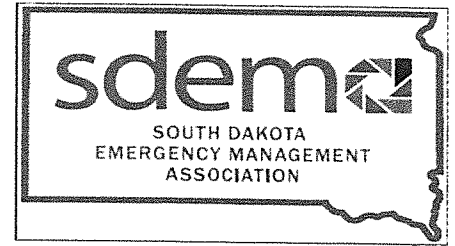

Date: November 5, 2019

Subj: Commission Update

1. Threat Hazard Identification and Risk Assessment: The THIRA was completed and approved by Homeland Security on October 31, 2019. This is a LEMPG workplan requirement.
2. Battle Mountain Road: The work has been completed and the road is now passable. I am requesting approval for the county to fund \$1,500 as part of the overall cost.
3. Training: I participated in the ASFPM webinar on October 30, 2019 and received 1 CEU toward my Certified Floodplain Manager certification. I attended the OEM sponsored AWR 331 Winter Weather Hazards course in Rapid City on November 4, 2019.
4. Fires & Incidents:
 - 10/20/2019: Landfill fire: Edgemont Fire and Fall River Sheriff's Office.
 - 10/25/2019: Sig. 1 Accident Hwy 71 & 18 Bypass: Hot Springs Police, Fall River Sheriff's Office, Hot Springs Fire, Hot Springs Ambulance and SD Highway Patrol.

A handwritten signature in cursive script that reads "Franklin W. Maynard".

Franklin W. Maynard, CEM, CFM
Emergency Manager
Fall River County
906 N. River Street
Hot Springs, SD 57747

Aaron Eberle

From: Lyle Jensen [lyle.jensen@frcounty.org]
Sent: Wednesday, October 23, 2019 9:46 AM
To: Sue; Aaron Eberle
Subject: Fwd: GWT: Security Total Care Quote

----- Forwarded message -----

From: Eric Eisenbraun <EricEisenbraun@goldenwest.com>
Date: Wed, Oct 23, 2019 at 8:59 AM
Subject: RE: GWT: Security Total Care Quote
To: Lyle Jensen <lyle.jensen@frcounty.org>

Unit Unit type Manufacturer Product type

Annex Door	Access control	HID	EH400
AXIS P7216 Group 1 - ACCC8E8120C8	Video	Axis	AXIS P7216
AXIS P7216 Group 2 - ACCC8E8120C9	Video	Axis	AXIS P7216
AXIS P7216 Group 3 - ACCC8E8120CA	Video	Axis	AXIS P7216
AXIS P7216 Group 4- ACCC8E8120CA	Video	Axis	AXIS P7216
Booking Room	Video	Axis	AXIS Q3504
Clerk of Courts	Access control	HID	EH400
Courthouse 1st Floor ACU	Access control	HID	EH400
Courthouse 2nd Floor West ACU	Access control	HID	EH400

Courthouse Alley Door	Access control	HID	EH400
Courthouse Basement Front Door ACU	Access control	HID	EH400
Evidence Room ACU	Access control	HID	EH400
Evidence Room Door	Video	Axis	AXIS P3225-V Mk II
Jail Garage Door ACU	Access control	HID	EH400
Jail Main Door ACU	Access control	HID	EH400
Jail Office Door ACU	Access control	HID	EH400
THC1	Video	Axis	AXIS P3225-V Mk II

From: Lyle Jensen <lyle.jensen@frcounty.org>
Sent: Tuesday, October 22, 2019 3:13 PM
To: Eric Eisenbraun <EricEisenbraun@goldenwest.com>
Subject: Re: GWT: Security Total Care Quote

Hi Eric

I don't see the list of equipment covered could you submit it ?

Thanks

On Fri, Sep 20, 2019 at 3:44 PM Eric Eisenbraun <EricEisenbraun@goldenwest.com> wrote:

Lyle,

Attached is the quote for Security Total Care. This would be a monthly addition to your recurring services invoice.

From our last QBR, we discussed adding this to ensure the Genetec server stays current on security patches. Let me know if you have any questions.

Eric Eisenbraun

Golden West vCIO

Toll Free: 800.529.0111 | Direct: 605.719.3639 | Cell: 605.863.0890



--

Lyle Jensen

Maintenance Supervisor

Fall River & Oglala Lakota County

Hot Springs SD 57747

Office 605-745-5144

Cell 605-890-0372

--

Lyle Jensen

Maintenance Supervisor

Fall River & Oglala Lakota County

Hot Springs SD 57747

Office 605-745-5144
Cell 605-890-0372

Use of dynamic brake device prohibited.

A. Except as provided in this section, the use or operation of a dynamic braking device on unmuffled vehicles is hereby prohibited within Fall River County at the locations set out as follows:

Zone 1 – Highway 385 milepost #38, 1 1/4 miles north of Hot Springs traveling south-east to intersection with Highway 79.

Zone 2 – Highway 18 milepost #33, 1 1/2 miles west of Hot Springs traveling east to intersection with Highway 385.

Zone 3 - Highway 79 milepost #28, 1 1/3 miles north of junction with Highway 385/18, traveling south to Cheyenne River at milepost #46.

B. A dynamic braking device is a device used on vehicles that converts the engine from an internal combustion engine to an air compressor for the purpose of braking without the use of wheel brakes. These devices are commonly referred to as “air brakes,” “engine brakes,” “compression brakes,” “Jacob’s Brakes,” or “Jake Brakes.”

C. This section shall not apply to State/County/City emergency vehicles, whether or not responding to an emergency.

D. As an affirmative defense to a charge of a violating of this section, the driver of the vehicle must prove by a preponderance of the evidence that:

1. The driver of the vehicle was operating the vehicle in compliance with all applicable laws at the time the unmuffled dynamic braking device was used; and
2. The speed of vehicle was reasonable given all of the relevant circumstances; and
3. The driver believed that the use of the unmuffled dynamic braking device was necessary to either:
 - a. Avoid an imminent threat to the safety of the driver or any other person; or
 - b. Avoid an imminent threat to property.
4. The driver’s belief as to the necessity for using the unmuffled dynamic braking device was objectively reasonable.

E. A violation of this ordinance shall be subject to a fine of \$_____ per violation.

**NOTICE OF HEARING FOR CONSIDERATION OF
VACATION OF PUBLIC RIGHT-OF-WAY**

NOTICE IS HEREBY GIVEN that the Fall River County Board of Commissioners, pursuant to the provisions of SDCL 31-3-6 and SDCL 31-3-7, will hold a public hearing a 9:30 a.m. on November 5, 2019 in the Fall River County Courthouse, Section Floor, Courtroom, 906 N. River St., Hot Springs, South Dakota, to consider a Petition to vacate a public right-of-way, having been proposed to be vacated:

1. A 66' wide section wide highway between Section 22, Township 7 South, Range 5 East of the Black Hills Meridian, Fall River County, South Dakota and Section 27, Township 7 South, Range 5 East of the Black Hills Meridian, Fall River County, South Dakota, running between McCarthy Tract in Section 27 and Lots 15 and 16 in Section 22, as set forth on the Plat of McCarthy Tract dated October 7, 2016 and filed in the office of the Register of Deeds for Fall River County, South Dakota, in Book XXVII, page 54, beginning at the SE corner of Lot 16 in the NE corner of McCarthy Tract and traveling west to the SW corner of Lot 15 and the NW corner of McCarty Tract.

Interested persons may present oral testimony at the hearing. Written comments will be received at the office of the County Auditor, 906 N. River St., Hot Springs, South Dakota, 57747, up until the date and time set for the public hearing.

Dated: August 20, 2019.

/s/Sue Ganje, County Auditor

Published twice at the total of approximate cost of \$_____

PREPARED BY:
Jane M. Farrell
FARRELL, FARRELL & GINSBACH, PC
441 N. RIVER STREET
HOT SPRINGS, SD 57747
605-745-5161

PETITION TO VACATE SECTION LINE RIGHT OF WAY

TO THE FALL RIVER COUNTY COMMISSIONERS:

WE, THE UNDERSIGNED qualified voters of Fall River County in the State of South Dakota, pursuant to SDCL 31-3-6, petition the Fall River County Commission to vacate the below listed section line highways , as the public interest will be better served by the proposed vacating of the section line highways:

1. The beginning, course and termination of the section line highways to be vacated are as follows:

That portion of the section line between Section 22 Township 7 South, Range 5 East of the Black Hills Meridian, Fall River County, South Dakota and Section 27, Township 7 South, Range 5 East of the Black Hills Meridian, Fall River County, South Dakota running between McCarthy Tract in Section 27 and Lots 15 and 16 in Section 22, as set forth on the Plat of McCarthy Tract dated October 7, 2016 and filed in the Office of the Register of Deeds for Fall River County, South Dakota in Book XXVII on page 54, attached hereto as Exhibit A, beginning at the southeast corner of Lot 16 and the northeast corner of McCarthy Tract and travelling west to the southwest corner of Lot 15 and the northwest corner of McCarthy Tract.

2. The landowners adjacent to the location of the section line highways are:

Robert and Debra McCarthy
12689 Ridgeview Rd.
Hot Springs, SD 57747

Sheryl L. Sether
12687 Ridgeview Dr.
Hot Springs, SD 57747

Brandon Pavelka
 12675 Ridgeview Dr.
 Hot Springs, SD 57747

MCCARTHY TRACT LOCATED IN THE NW 1/4 OF SECTION 27 AND A PRIVATE ACCESS AND UTILITY EASEMENT ACROSS TRACT M OF BLOCK G OF COUNTRY CLUB ESTATES, LOCATED IN THE NW 1/4 NE 1/4 OF SECTION 27 AND THE SW 1/4 SE 1/4 OF SECTION 22, ALL IN T7S, R5E, B11A, FALL RIVER COUNTY, SOUTH DAKOTA

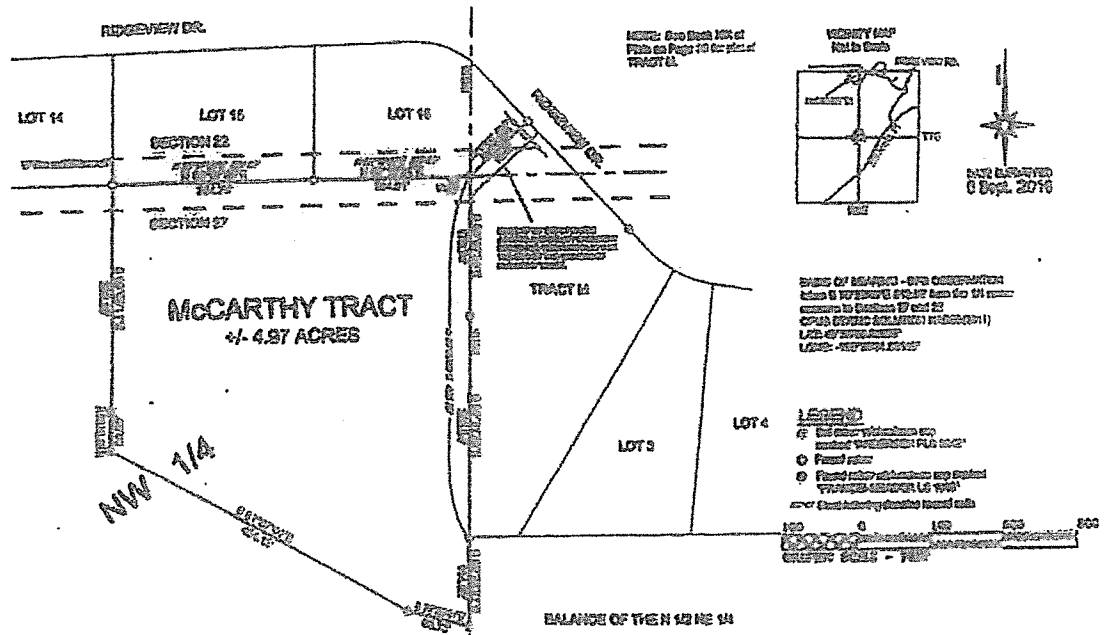

SECTION LINE RIGHT OF WAY TO VACATE
 HIGHLIGHTED IN ORANGE

1. Signers of this petition must individually sign their names in the form in which they are registered to vote or as they usually sign their names.

2. Before the petition is filed, each signer or the circulator must add the residence address of the signer and the date of signing. If the signer is a resident of a second or third class municipality, a post office box may be used for the residence address.

3. Before the petition is filed, each signer or the circulator must print the name of the signer in the space provided and add the county of voter registration.

4. Abbreviations of common usage may be used. Ditto marks may not be used.

5. Failure to provide all information requested may invalidate the signature.

NAME		RESIDENCE	DATE/COUNTY
SIGN		STREET AND NUMBER OR RURAL ROUTE AND BOX NUMBER	DATE OF SIGNING
PRINT		CITY OR TOWN	COUNTY OF REGISTRATION
1	<i>J. Edwin Coates</i> J. Edwin Coates	12754 Clubview HOT SPRINGS S.D.	11/15/17 Fall River
2	<i>Jean Nachtigall</i> Jean Nachtigall	12749 COUNTRY Rd HOT SPRINGS S.D. SD	11-15-17 Fall River
3	<i>Lindsey Pavelka</i> LINDSEY PAVELKA	12675 Ridgeview Dr HOT SPRINGS SD 57747	11-15-17 Fall River
4	<i>Lindsey Pavelka</i> Lindsey Pavelka	12675 Ridgeview Drive HOT SPRINGS SD 57747	11/15/17 Fall River
5	<i>Robert N Metzger</i> Robert N Metzger	12887 Ridgeview Dr HOT SPRINGS S	11/15/17 Fall River
6	<i>Juanita Holley</i> Juanita Holley	12752 Clubview DR. HOT SPRINGS	11-15-17 Fall River
7	<i>Ed Holley</i> Ed Holley	12752 Clubview DR. HOT SPRINGS	11-15-17 Fall River
8	<i>Virginia D. Coates</i> Virginia D. Coates	12754 Clubview DR. HOT SPRINGS SD	11-15-17 Fall River
9	<i>Stachia Walker</i> Stachia Walker	12700 Ridgeview DR HOT SPRINGS SD	11/16/17 Fall River
10	<i>Patricia Martin</i> Patricia Martin	309 Canton HOT SPRINGS SD	11/16/17 Fall River
11	<i>Bethany Friesen</i> Bethany Friesen	1501 Martin St HOT SPRINGS SD 57747	11/16/17 Fall River
12	<i>Barbara Walter</i> BARBARA WALTER	648 S 16th St Apt C1 HOT SPRINGS SD 57747	11-16-17 Fall River
13	<i>Scott Harkless</i> Scott Harkless	2205 Wilson Ave HOT SPRINGS SD 57747	11-16-17 Fall River
14	<i>Elizabeth Meyer</i> Elizabeth Meyer	12624 Sandstone Rd HOT SPRINGS SD 57747	11-17-17 Fall River
15	<i>Karen M Meston</i> Karen M Meston	12175 Hot Break Canyon Rd HOT SPRINGS SD 57747	11/17/17 Fall River

16 SIGN Marilyn Rowley PRINT Marilyn Rowley	401 N. 6th Street CITY OR TOWN Hot Springs	11-17-2017 COUNTY OF REGISTRATION Fall River
17 SIGN Ruth Angerhofer PRINT Ruth Angerhofer	STREET AND NUMBER OR RURAL ROUTE AND BOX NUMBER 305 Lincoln Ave CITY OR TOWN Hot Springs	DATE OF SIGNING COUNTY OF REGISTRATION
18 SIGN PRINT	STREET AND NUMBER OR RURAL ROUTE AND BOX NUMBER CITY OR TOWN	DATE OF SIGNING COUNTY OF REGISTRATION
19 SIGN PRINT	STREET AND NUMBER OR RURAL ROUTE AND BOX NUMBER CITY OR TOWN	DATE OF SIGNING COUNTY OF REGISTRATION
20 SIGN PRINT	STREET AND NUMBER OR RURAL ROUTE AND BOX NUMBER CITY OR TOWN	DATE OF SIGNING COUNTY OF REGISTRATION

VERIFICATION BY PERSON CIRCULATING PETITION

INSTRUCTIONS TO CIRCULATOR: This section must be completed following circulation and before filing.

J. Edwin Coates 12754 Clubview Hot Springs, SD.
 Print name of the circulator Residence Address City State

I, under oath, state that I circulated the above petition, that each signer personally signed this petition in my presence, and that either the signer or I added the printed name, the residence address of the signer, the date of signing, and the county of voter registration.

J. Edwin Coates
 Signature of Circulator

Sworn to before me this 20th day of November, 2017.
 (Seal)

Shari Elizabeth Winslow
 Signature of Officer Administering Oath
Recal Assistant
 Title of Officer Administering Oath

My Commission Expires 12-30-2020
 Form Revised 2005 - 5:02:08:21



My Commission Expires
 December 30, 2020

AND THE SW 1/4 SE 1/4 OF SECTION 22, ALL IN T7S, R5E, B1M, FALL RIVER COUNTY, SOUTH DAKOTA

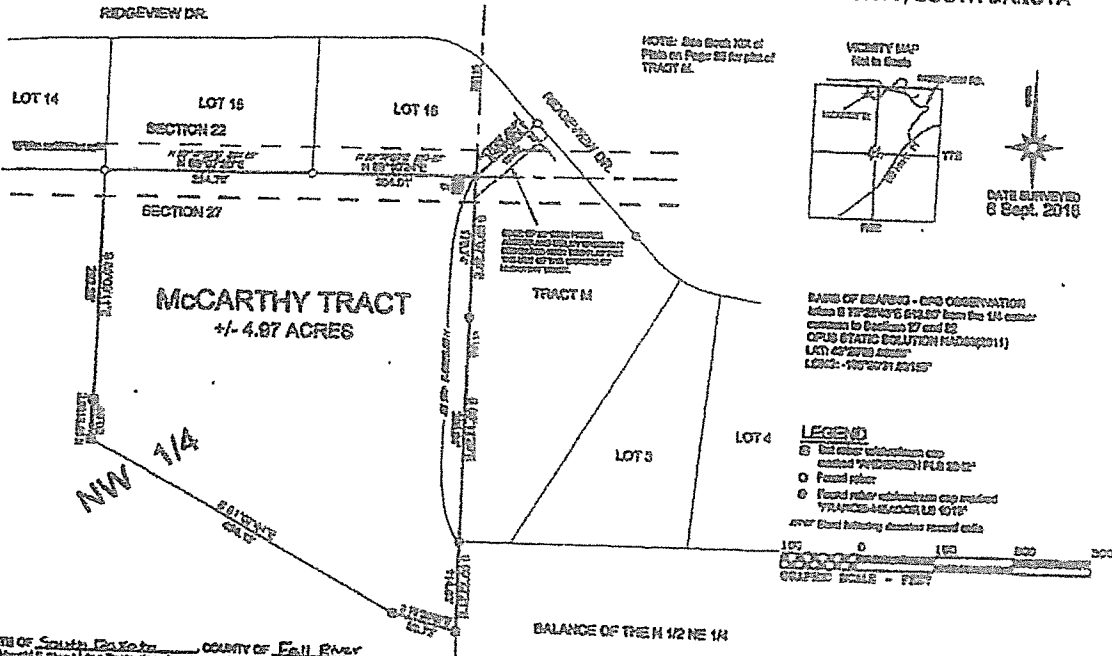

STATE OF South Dakota, COUNTY OF Fall River
 I, Shirley F. Blag, being duly sworn, do hereby certify that I am the owner of the within described lands and that the within plat was made in the presence of the persons indicated therein, and that the development of this land shall conform to all existing zoning, subdivision, and covenants and uniform control regulations.
 Witness my hand and official seal this 28th day of Sept., 2018.

Shirley F. Blag
 Shirley F. Blag (Trustee)

ACKNOWLEDGMENT OF OWNERSHIP
 STATE OF South Dakota, COUNTY OF Fall River
 I, Shirley F. Blag, being duly sworn, do hereby certify that I am the owner of the within described lands and that the within plat was made in the presence of the persons indicated therein, and that the development of this land shall conform to all existing zoning, subdivision, and covenants and uniform control regulations.
 Witness my hand and official seal this 28th day of Sept., 2018.

Shirley F. Blag
 Shirley F. Blag
 by commission expires April 25, 2020



CERTIFICATE OF REGISTER
 I, Keith E. Anderson, Registered Land Surveyor No. 2824 in the State of South Dakota, do hereby certify that being so authorized, I have prepared the within plat of land shown and described herein from either taken during an actual survey made by me or under my direct supervision, and that the same is a true and correct representation of said survey.
 IN WITNESS WHEREOF, I have hereunto set my hand and official seal this 28th day of Sept., 2018.



CERTIFICATE OF COUNTY DIRECTOR OF REGISTRATION
 I, Director of Registration of Fall River County, do hereby certify that any copy hereon has been furnished with a true copy of the within plat.
 Dated this 28th day of Sept., 2018.

Christina Paulsen
 Christina Paulsen
 County Director of Registration of Fall River County

CERTIFICATE OF COUNTY TREASURER
 I, Fall River County Treasurer, do hereby certify that all taxes and charges due and payable on the within described lands are fully paid according to the records of this office.
 Dated this 28th day of Sept., 2018.



CERTIFICATE OF HIGHWAY AGENCY
 It appears that every lot has its appropriate approval location and the location of the improvement of the proposed subdivision comply with the existing public utility to be improved.
 Dated this 10th day of Sept., 2018.

RESOLUTION OF THE BOARD OF COUNTY COMMISSIONERS
 Whereas, there has been submitted to the County Commissioners of Fall River County, South Dakota, the within plat of the above described lands, and it appearing to the Board that the system of streets conforms to the system of streets of existing plats and within laws of the County, whereas provision is made for access to adjacent unimproved lands by public easements or easements the same being already existing; all provisions of the County subdivision regulations have been complied with; all taxes and special assessments upon the property have been paid; and the plat and survey have been found to be correct and true and valid.
 BE IT RESOLVED THAT said plat is hereby approved to all intents.
 Dated this 10th day of Sept., 2018.

Michael Blag
 Michael Blag
 Chairman, Fall River County Board of Commissioners

CERTIFICATE OF COUNTY AUDITOR
 I, Fall River County Auditor, do hereby certify that the above instrument is a true and correct copy of the resolution adopted by the Board of County Commissioners of Fall River County, South Dakota, at a meeting held on the 28th day of September, 2018.

John A. Aice
 John A. Aice
 Fall River County Auditor

ACKNOWLEDGMENT OF OWNERSHIP
 STATE OF South Dakota, COUNTY OF Fall River
 I, Shirley F. Blag, being duly sworn, do hereby certify that I am the owner of the within described lands and that the within plat was made in the presence of the persons indicated therein, and that the development of this land shall conform to all existing zoning, subdivision, and covenants and uniform control regulations.
 Witness my hand and official seal this 28th day of Sept., 2018.

Shirley F. Blag
 Shirley F. Blag (Trustee)

ACKNOWLEDGMENT OF OWNERSHIP
 STATE OF South Dakota, COUNTY OF Fall River
 I, Shirley F. Blag, being duly sworn, do hereby certify that I am the owner of the within described lands and that the within plat was made in the presence of the persons indicated therein, and that the development of this land shall conform to all existing zoning, subdivision, and covenants and uniform control regulations.
 Witness my hand and official seal this 28th day of Sept., 2018.

Shirley F. Blag
 Shirley F. Blag
 by commission expires April 25, 2020

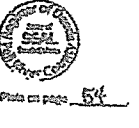

Prepared by
ANDERSEN ENGINEERS
 Lead Surveyor, Registered Professional Engineer, & Environmental Scientist

Drawn by DA	Date 8/13/2018	P.L. Box 443 Espeland, SD 57525 (605) 622-5500
Approved by SEA	Date 8/13/2018	anderson@anderseneng.com

DEED OF THE REGISTER OF DEEDS
 I, Wade C. Jacobson, 2018, at 4:10 PM, October 2, 2018, and returned to Book XXVII, of Plats on page 54

Wade C. Jacobson
 Wade C. Jacobson

3

Exhibit A

June, 15, 2017

Mr. Bob McCarthy,

The Board of Country Club Estates has looked at your proposal to vacate the section line along lots 15 and 16 of Country Club Estates; and the board has no objections to the vacation of that section line.

Sincerely,

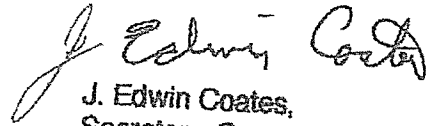
A handwritten signature in cursive script that reads "J. Edwin Coates". The signature is written in black ink and is positioned above the typed name.

J. Edwin Coates,
Secretary, Country Club Estates

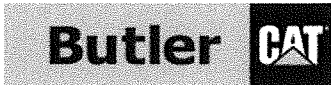

ORIGINAL

October 25, 2019

BOARD OF COMMISSIONERS
 FALL RIVER COUNTY
 HIGHWAY DEPARTMENT
 HOT SPRINGS, South Dakota 57747-1398

Dear Fall River Board of Commissioners

We are pleased to quote the following for your consideration

PER SOURCEWELL COOPERATIVE PURCHASING CONTRACT #032515 CAT 2019

CATERPILLAR Model: 259D3 COMPACT TRACK LOADER

STOCK NUMBER: M027146

SERIAL NUMBER:

YEAR: 2020

SMU: 0

CATERPILLAR Model: 259D3 COMPACT TRACK LOADER

STANDARD EQUIPMENT

POWERTRAIN - Cat C3.3B diesel engine - -Gross horsepower per SAE J1349 - 74.3 hp (55.4 kW) @ 2400 RPM - -Electric fuel priming pump - -Glow plugs starting aid - -Liquid cooled, direct injection - Air cleaner, dual element, radial seal - S-O-S sampling valve, hydraulic oil - Filter, cartridge type, hydraulic - Filters, canister type, fuel - and water separator - Radiator / hydraulic oil - cooler (side-by-side) - Spring applied, hydraulically released, - parking brakes - Hydrostatic transmission

UNDERCARRIAGE - Suspension - independent torsion axle(4) - Two speed motor

HYDRAULICS - ISO or H pattern controls: - Electro/hydraulic implement control - Electro/hydraulic hydrostatic - transmission control - Speed sensor guarding -

ELECTRICAL - 12 volt electrical system - 80 ampere alternator - Ignition key start / stop / aux switch - Lights: - -Gauge backlighting - -Two rear tail lights - -Dome light - Backup alarm - Electrical outlet, beacon -

OPERATOR ENVIRONMENT - Operator warning system indicators: - -Air filter restriction - -Alternator output - -Armrest raised / operator out of seat - -Engine coolant temperature - -Engine oil pressure - -Glow plug activation - -Hydraulic filter restriction - -Hydraulic oil temperature - -Park brake engages - -Engine emission system - Gauges: fuel level and hour meter - Storage compartment with netting - Ergonomic contoured armrest - Control interlock dystem, when operator - leaves seat or armrest raised: - -Hydraulic system disables - -Hydrostatic transmission disables - -Parking brake engages - ROPS cab, open, tilt up - Anti-theft security system w/6-button - keypad - FOPS, Level I - Top and rear windows - Floormat - Interior rear view mirror - USB charging port - Horn - Hand (dial) throttle, electronic -

FRAMES - Lift linkage, vertical path - Chassis, one piece welded - Machine tie down points (6) - Belly pan cleanout - Support, lift arm - Rear bumper, welded

OTHER STANDARD EQUIPMENT - Engine enclosure - lockable - Extended life antifreeze (-37C, -34F) - Work tool coupler - Hydraulic oil level sight gauge - Radiator coolant level sight gauge - Radiator expansion bottle - Cat ToughGuard TM hose - Heavy duty flat faced quick disconnects - with integrated pressure release - Split D-ring to route work tool hoses - along side of left lift arm - Hydraulic demand cooling fan - Per SAE J818-2007 and EN 474-3:2006 and - ISO 14397-1:2007

MACHINE SPECIFICATIONS

259D3 COMPACT TRACK LOADER	SEAT BELT, 2"
RUBBER BELT, 2 SPD, TF IDLERS	RADIO, AM/FM, BLUETOOTH
TRACK,RUBBER,400MM(15.7 IN)BAR	DISPLAY, ADVANCED, LCD, CAMERA
HYDRAULICS, PERFORMANCE, (H2) STANDARD FLOW	FAN, COOLING, DEMAND
CONTROL, ISO, PROP, WT	QUICK COUPLER, HYDRAULIC
RIDE CONTROL	FILM, TWO SPEED
BATTERY, HEAVY DUTY, 850 CCA	HEATER, ENGINE COOLANT, 120V
LIGHTS, HALOGEN	COUNTERWEIGHT,MACHINE,EXTERNAL
REAR LIGHTS	OIL, HYDRAULIC, COLD OPERATION
ROPS, ENCLOSED WITH A/C (C3)	PRODUCT LINK, CELLULAR PL243 (not activated)
SEAT,AIR SUSPENSION,CLOTH,HEAT	BUCKET-GP, 80", BOCE - X049105
DOOR, CAB, POLYCARBONATE	

WARRANTY

Standard Warranty: 24 Months / 2000 Hours Standard Warranty excluding Mileage

F.O.B/TERMS: Fall River County

SELL PRICE	\$53,565.00
Optional 48" CAT Pallet Forks	\$886.00
72" CAT BRUSHCUTTER	\$5,380.00

Accepted by _____ on _____

Signature

We believe the equipment as quoted will exceed your expectations. Thank you for the opportunity to quote this equipment.

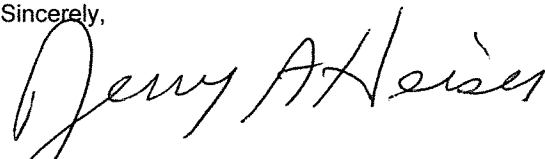
Sincerely,

Jerry Heiser
Machine Sales Representative JerryHeiser@buttermachinery.com
605-209-4671

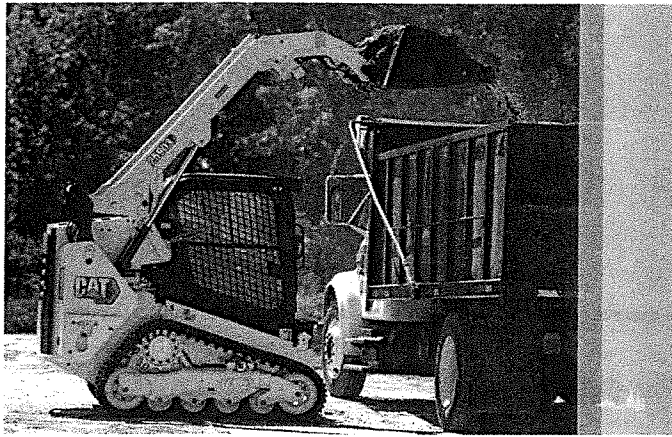

Cat[®] 259D3

COMPACT TRACK LOADER

FEATURES:

The Cat[®] 259D3 Compact Track Loader, with its vertical lift design, delivers extended reach and lift height for quick and easy truck loading. Its standard, suspended undercarriage system provides superior traction, flotation, stability and speed to work in a wide range of applications and underfoot conditions. The 259D3 features the following:

- **Industry leading sealed and pressurized cab option** provides a cleaner and quieter operating environment with excellent work tool visibility.
- **Available high-back, heated, air ride seat with seat mounted adjustable joystick controls** makes the D3 Series the industry leader in operator comfort.
- **High performance power train** provides maximum performance and production capability through the Electronic Torque Management system, standard two speed travel and an electronic hand/foot throttle with decel pedal capability.
- **High Flow hydraulic system** is available for applications that demand maximum hydraulic work tool performance.
- **Electronically controlled Cat C3.3B engine** provides high horsepower and torque while meeting U.S. EPA Tier 4 Final and EU Stage V emission standards.
- **Cat "Intelligent Leveling" system** provides industry leading technology, integration, and available features such as dual direction self level, work tool return to dig, and work tool positioner.
- **Standard fully independent torsion axle suspension** combined with the optional Speed Sensitive Ride Control system improves operation on rough terrain, enabling better load retention, increased productivity and greater operator comfort.
- **Maximize machine capability and control** with optional Advanced Display providing on-screen adjustments for implement response, hystat response and creep control. Also features multi-language functionality with customizable layouts, security system and rearview camera.
- **Ground level access** to all daily service and routine maintenance points helps reduce machine downtime for greater productivity.
- **Broad range of performance matched Cat Work Tools** make the Cat Compact Track Loader the most versatile machine on the job site.

Specifications

Engine

Engine Model	Cat C3.3B DIT (turbo)	
Gross Power SAE J1995	55.4 kW	74.3 hp
Net Power SAE 1349	54.6 kW	73.2 hp
Net Power ISO 9249	55.1 kW	73.9 hp
Peak Torque at 1,500 rpm SAE J1995	265 N-m	195 lbf-ft
Displacement	3.3 L	203 in ³
Stroke	120 mm	4.7 in
Bore	94 mm	3.7 in

Weights*

Operating Weight	4076 kg	8,987 lb
------------------	---------	----------

*Operating Weight, Operating Specifications and Dimensions all based on 75 kg (165 lb) operator, all fluids, two speed, OROPS, 1730 mm (68 in) low profile bucket, 320 mm (12.6 in) tracks, dual flange front idler/single flange rear idler, standard flow hydraulics, mechanical suspension seat, no optional counterweights and manual quick coupler (unless otherwise noted).

Power Train

Travel Speed (Forward or Reverse)			
One Speed	9.5 km/h	5.9 mph	
Two Speed	13.7 km/h	8.5 mph	

Hydraulic System

Hydraulic Flow – Standard:			
Loader Hydraulic Pressure	23 000 kPa	3,335 psi	
Loader Hydraulic Flow	76 L/min	20 gal/min	
Hydraulic Power (calculated)	29 kW	39 hp	
Hydraulic Flow – High Flow:			
Loader Hydraulic Pressure	23 000 kPa	3,335 psi	
Loader Hydraulic Flow	112 L/min	30 gal/min	
Hydraulic Power (calculated)	43 kW	58 hp	



259D3 Compact Track Loader

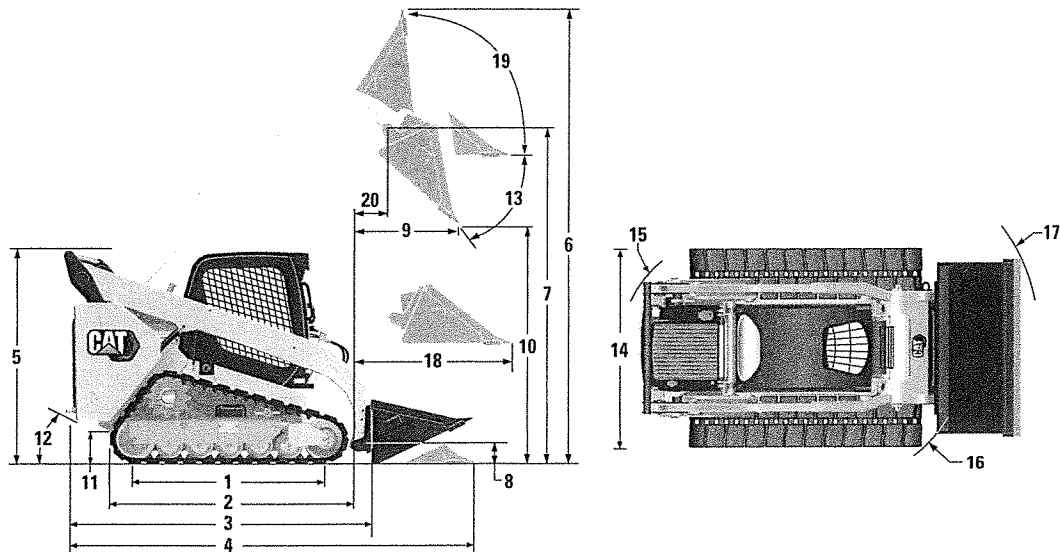

Dimensions*

1 Length of Track on Ground	1499 mm	59.0 in	12 Departure Angle	35°
2 Overall Length of Track	1999 mm	78.7 in	13 Maximum Dump Angle	52°
3 Length without Bucket	2767 mm	108.9 in	14 Vehicle Width (320 mm/12.6 in tracks)	1676 mm 66.0 in
4 Length with Bucket on Ground	3486 mm	137.3 in	Vehicle Width (400 mm/15.7 in tracks)	1755 mm 69.0 in
5 Height to Top of Cab	2111 mm	83.1 in	15 Turning Radius from Center – Machine Rear	1561 mm 61.5 in
6 Maximum Overall Height	3915 mm	154.1 in	16 Turning Radius from Center – Coupler	1392 mm 54.8 in
7 Bucket Pin Height at Maximum Lift	3075 mm	121.0 in	17 Turning Radius from Center – Bucket	2184 mm 86.0 in
8 Bucket Pin Height at Carry Position	198 mm	7.8 in	18 Maximum Reach with Arms Parallel to Ground	1305 mm 51.4 in
9 Reach at Maximum Lift and Dump	608 mm	23.9 in	19 Rack Back Angle at Maximum Height	87°
10 Clearance at Maximum Lift and Dump	2283 mm	89.9 in	20 Bucket Pin Reach at Maximum Lift	238 mm 9.4 in
11 Ground Clearance	226 mm	8.9 in		

Operating Specifications*

Rated Operating Capacity:		
35% Tipping Load	915 kg	2,010 lb
50% Tipping Load	1305 kg	2,870 lb
Rated Operating Capacity with Optional Counterweight		
Tipping Load	1390 kg	3,060 lb
Breakout Force, Tilt Cylinder	2252 kg	4,965 lb
Ground Contact Area (320 mm/12.6 in track)	0.96 m ²	1,483 in ²
Ground Contact Area (400 mm/15.7 in track)	1.19 m ²	1,848 in ²
Ground Pressure (320 mm/12.6 in track)	41.8 kPa	6.1 psi
Ground Pressure (400 mm/15.7 in track)	34.0 kPa	4.9 psi

Cab

ROPS	ISO 3471:2008
FOPS	ISO 3449:2005 Level I

Service Refill Capacities

Cooling System	14 L	3.7 gal
Engine Crankcase	11 L	3.0 gal
Fuel Tank	94 L	24.8 gal
Hydraulic System	50 L	13.2 gal
Hydraulic Tank	39 L	10.3 gal

Noise Level

Inside Cab**	83 dB(A)
Outside Cab***	103 dB(A)

- Cab and Rollover Protective Structures (ROPS) are standard in North America and Europe.

**The declared dynamic operator sound pressure levels per ISO 6396:2008. The measurements were conducted with the cab doors and windows closed and at 70% of the maximum engine cooling fan speed. The sound level may vary at different engine cooling fan speeds.

***The labeled sound power level for the CE marked configurations when measured according to the test procedure and conditions specified in 2000/14/EC.

Air Conditioning System (if equipped)

The air conditioning system on this machine contains the fluorinated greenhouse gas refrigerant R134a (Global Warming Potential = 1430). The system contains 0.81 kg of refrigerant which has a CO₂ equivalent of 1.158 metric tonnes.

MANDATORY EQUIPMENT

- Hydraulics, Standard or High Flow
- Quick Coupler, Mechanical or Powered
- High Visibility Seat Belt, 50 mm (2 in) or 75 mm (3 in)
- EU Preparation Package
- Steel Imbed Rubber Track – 320 mm (12.6 in) or 400 mm (15.7 in)
- Dual Flange Front Idler/Single Flange Rear Idler or Triple Flange Front/Rear Idlers

PERFORMANCE PACKAGES

- Performance Package H1: *Standard Flow Hydraulics (No Self Level)*
- Performance Package H2: *Standard Flow Hydraulics, Dual Direction Electronic Self Level (Raise and Lower), Work Tool Return to Dig, Work Tool Positioner, and Electronic Snubbing (Raise and Lower)*
- Performance Package H3: *High Flow Hydraulics, Dual Direction Electronic Self Level (Raise and Lower), Work Tool Return to Dig, Work Tool Positioner, and Electronic Snubbing (Raise and Lower)*

STANDARD EQUIPMENT

ELECTRICAL

- 12 volt Electrical System
- 80 ampere Alternator
- Ignition Key Start/Stop Switch
- Lights: *Gauge Backlighting, Two Rear Tail Lights, Two Adjustable Front and Rear Halogen Lights, Dome Light*
- Backup Alarm
- Heavy Duty Battery, 850 CCA

OPERATOR ENVIRONMENT

- Advanced Display with Rearview Camera: *Full Color, 127 mm (5 in) LCD screen; Advanced Multi-operator Security System; On-screen Adjustments for Implement Response, Hystat Response, and Creep Control*
- Gauges: *Fuel Level, Hour Meter*
- Operator Warning System Indicators: *Air Filter Restriction, Alternator Output, Armrest Raised/Operator Out of Seat, Engine Coolant Temperature, Engine Oil Pressure, Glow Plug Activation, Hydraulic Filter Restriction, Hydraulic Oil Temperature, Park Brake Engaged, Engine Emission System*
- Adjustable Vinyl Seat
- Fold In Ergonomic Contoured Armrest
- Control Interlock System, when operator leaves seat or armrest raised: *Hydraulic System Disables, Hydrostatic Transmission Disables, Parking Brake Engages*
- ROPS Cab, Open, Tilt Up
- FOPS, Level I
- Top and Rear Windows
- Floor Mat
- Interior Rearview Mirror
- 12 volt Electric Socket
- Horn
- Hand (Dial) Throttle, Electronic
- Adjustable Joystick Controls
- Anti-theft Security System with 6-button Keypad
- Storage Compartment with Netting

COMFORT PACKAGES

- Open ROPS (C0): *Static Seat (No Foot Throttle, Headliner, Heater or Door)*
- Open ROPS (C1): *Foot Throttle, Headliner, Cup Holder, and choice of Seat (Mechanical Suspension or High Back, Heated, Air Ride Seat) (No Heater or Door)*
- Enclosed ROPS with Heater (C2): *Foot Throttle, Headliner, Heater and Defroster, Side Windows, Cup Holder, Radio Ready, choice of Seat (Mechanical Suspension or High Back, Heated, Air Ride Seat) and Door (Glass or Polycarbonate)*
- Enclosed ROPS with A/C (C3): *C2 + Air Conditioner*

POWER TRAIN

- Cat C3.3B, Turbo Diesel Engine, Meeting Tier 4 Final and Stage V Emission Standards
- Air Cleaner, Dual Element, Radial Seal
- S-O-SSM Sampling Valve, Hydraulic Oil
- Filters, Cartridge-type, Hydraulic
- Filters, Canister-type, Fuel and Water Separator
- Radiator/Hydraulic Oil Cooler (side-by-side)
- Spring Applied, Hydraulically Released Parking Brakes
- Hydrostatic Transmission, Two Speed Travel
- Suspension – Independent Torsion Axles (4)

OTHER

- Engine Enclosure, Lockable
- Extended Life Antifreeze, -36° C (-33° F)
- Machine Tie Down Points (6)
- Support, Lift Arm
- Hydraulic Oil Level Sight Gauge
- Radiator Coolant Level Sight Gauge
- Radiator, Expansion Bottle
- Cat ToughGuard™ Hose
- Auxiliary, Hydraulics, Continuous Flow
- Heavy Duty, Flat Faced Quick Disconnects with Integrated Pressure Release
- Split D-Ring to Route Work Tool Hoses Along Side of Left Lift Arm
- Electrical Outlet, Beacon
- Belly Pan Cleanout
- Variable Speed Demand Fan
- Product Link™ PL240, Cellular

259D3 Compact Track Loader

OPTIONAL EQUIPMENT

- Hand-Foot Style Controls
- External Counterweights
- Beacon, Rotating
- Engine Block Heater – 120V
- Oil, Hydraulic, Cold Operation
- Paint, Custom
- Product Link PL641, Cellular
- Speed Sensitive Ride Control
- Bluetooth® Radio with Microphone (AM/FM/Weather Band Receiver with USB and Auxiliary Input Jack)

For more complete information on Cat products, dealer services, and industry solutions, visit us on the web at www.cat.com

© 2019 Caterpillar
All rights reserved

Materials and specifications are subject to change without notice. Featured machines in photos may include additional equipment. See your Cat dealer for available options.

CAT, CATERPILLAR, LET'S DO THE WORK, their respective logos, "Caterpillar Yellow," the "Power Edge" and Cat "Modern Hex" trade dress as well as corporate and product identity used herein, are trademarks of Caterpillar and may not be used without permission.

AEHQ8198-01 (08-2019)
Replaces AEHQ8198
(Am North, EU, APD, ANZP)



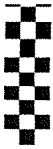

Mike Kulish

ACCEPTED ON

10/28/2019

Kn

From: noreply@mgoil.com
 Sent: Monday, October 28, 2019 11:47 AM
 To: Mike Kulish
 Cc: Todd Moe; MG Fuel
 Subject: RE: Fuel Details For Fall River County Hot Springs

Sent from Mkulish ()
 11:47 AM on Monday - October 28, 2019

Customer: Fall River County Hot Springs
 Truck/Train: Truck

Fuel	Delivered Price	Date
50/50 BLEND	2.48342	2019-10-28 08:23

M.G. Oil Company will not be held responsible or guarantee pricing of products when deliveries are disrupted due to supply.
 Confidentiality Notice: This email message, including any attachments, is for the sole use of the intended recipients and may contain confidential and privileged information. Any unauthorized review, use, disclosure or distribution is prohibited. If you are not the intended recipient, please contact the sender by reply email and destroy all copies of the original message and any attachment(s). Thank you.

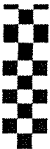

FAXED BID:

TO: FALL RIVER COUNTY HIGHWAY DEPT. FAX # 745-5912
PHONE # 745-5137

DATE: 10-28-19

FROM: Nelson's Oil & Gas, Inc.

PHONE: 745-4189
~~745-5137~~

BID FOR: 8000 gallons

AMOUNT OF BID: \$ 2.58 / gallon #1 / #2 Dyed
(This bid includes all appropriate taxes and fees) 50/50 Blend

Signed By: [Signature]
Richard Nelson

Note: all faxed bids must be received in the Fall River County Highway Dept. office at the above number before 12:00 p.m. to be considered, unless otherwise stated by the caller for bids. 12 pm (LATE CALL FOR BIDS)

If declining to bid please fax back this form with the words; "Decline today's bid." On the line designated for the Bid Amount

Thank You

won't deliver today

FAXED BID:

**TO: FALL RIVER COUNTY HIGHWAY DEPT. FAX # 745-5912
PHONE # 745-5137**

DATE: 10/28/2019

FROM: BILL TANNER FUEL PHONE: 890-1010

BID FOR: NO BID ON 4000 GAL #1 & 4000 GAL #2 DSL

AMOUNT OF BID: N/A - NOT PLACING TANKER ORDERS
(This bid includes all appropriate taxes and fees)

Signed By: [Signature] FOR BILL TANNER BY PHONE
K

Note: all faxed bids must be received in the Fall River County Highway Dept. office at the above number before 9:00 a.m. to be considered, unless otherwise stated by the caller for bids.

If declining to bid please fax back this form with the words; " Decline todays bid." On the line designated for the Bid Amount.

Thank You



October 11, 2019

Fall River County Hwy Department
Atten: Sue Ganje
906 N. River Str
Hot Springs, SD 57747

Ref: Slim Butte Road – Service to Verizon Cell Tower – 15000 US Hwy 18

Fall River County Commissioners:

Golden West Telecommunications has a telephone service request from Verizon Cell Tower at 15000 US Hwy 18 in the Oelrichs Golden West Exchange.

Enclosed is Fall River County utility permit application for the above referenced road. Also enclosed is a set of construction plans showing the proposed area of the bore.

When approved, please return the original permit application to my attention at PO Box 411 Crown Street, Wall, SD 57790.

If you have any questions, comments or concerns, please contact me directly at 605-279-1245 or e-mail bekkireinert@goldenwest.com.

Sincerely,

A handwritten signature in cursive script that reads "Bekki Reinert".

Bekki Reinert
Golden West Telecommunications
ROW Technician
PO Box 411
Wall, SD 57790
605-279-1245

Enclosures: 1

APPLICATION FOR PERMIT TO OCCUPY COUNTY HIGHWAY RIGHT-OF-WAY

TO: THE BOARD OF COUNTY COMMISSIONERS

DATE: 10/11/2019

FALL RIVER COUNTY,
HOT SPRINGS, SOUTH DAKOTA

Application is hereby made by Golden West Telecommunications, South Dakota for permit to occupy highway right-of-way located from: Intersection of US Hwy 18 and Slim Butte Rd
To: Bore under Slim Butte Road near this intersection

AERIAL FACILITIES: Location, type and size of the proposed line and anchors with respect to the centerline of the road or outer edge of the right-of-way and location of crossings showing any right-of-way are shown on Exhibit "A" (Sketch) attached.

UNDERGROUND FACILITIES: A sketch showing the approximate route and location of the proposed facility for which a permit is hereby requested is attached as Exhibit "A" and made a part hereof.

The following information is pertinent to the proposed installation:

1. Intended usage or rating: Placement of communication cable for Verizon Wireless
2. Pipe size, cable size and type: BFO 12
3. Outside diameter: N/A
4. Maximum pressure at which pipeline will be operated: N/A
5. Size and Type of metal casing: N/A
6. Minimum depth of cable or pipeline: Bore is 8' under road bed - toe of inslope to toe of inslope
7. Casing will be installed by minimum size boring and will extend from toe of in-slope to toe of in-slope.
8. This installation will comply with the most recently adopted ASA, Code for Gas Transmission and Distribution Pipe systems or the National Safety Code. Marker sign(s) will be installed where appropriate.

The installation and maintenance of said utility facilities will not interfere with or impair construction, maintenance or use of any highway and will comply with all safety regulations of the State and Federal Government. When trenching is done on County R.O.W. the trenches must be tamped to avoid any settlement.

Future adjustments and maintenance will be in accordance with State and Federal Laws and Regulations and will be performed at not cost to the County or the Federal Government.

APPROVED _____ 20 ____

SUBMITTED 22-Oct _____ 20 19

County Chairman

Golden West Telecommunications

County Auditor

By Becki Bennett for Golden West

Right-of-Way Technician

Title

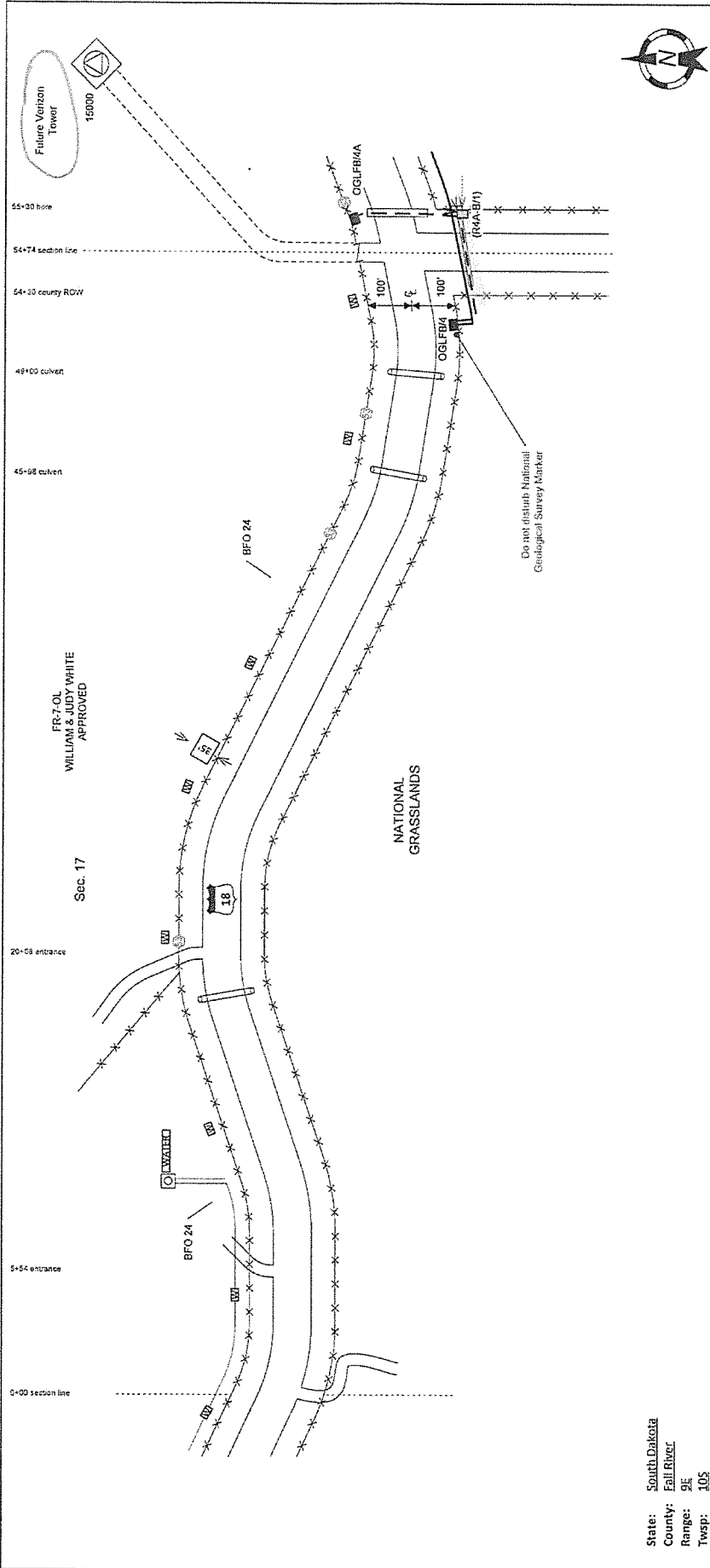

State: South Dakota
 County: Fall River
 Range: 2E
 Twp: 10S

CONFIDENTIAL
PROPERTY OF GOLDEN WEST
TELECOMMUNICATIONS

Bradeen Real Estate & Auctions
PO Box 686

Custer, SD 57730
Phone: 605-673-2629 Fax: 605-673-2620

CO #:	3062
Date:	10/3/2019
Page:	1

Consignor
 Fall River County
 906 N River St
 Hot Springs, SD 57747
 Phone:605-574-5145

Lot#	Transaction Description	Amount
	Total Quantity:	9.00
	Total Invoice Sale Price:	5,672.50
	Total Expenses: (331.17)
	Total Commission: (618.38)
	Total Due to Consignor:	4,722.95
	Total Payments:	0.00
	Balance:	\$4,722.95

Auction: City of Hot Springs Surplus Auction

Lot#	Transaction Description	Amount
71	1998 Ford F250 Ext Cab 4x4	
	Invoice Sale Price	1,000.00
	Bid Card # 1061	
72	1995 Ford F150 Ext Cab 4x4	
	Invoice Sale Price	1,325.00
	Bid Card # 1062	
73	1995 5000 Gallon Water Tanker	
	Invoice Sale Price	170.00
	Bid Card # 1072	
74	1975 John Deere 401-B Tractor	
	Invoice Sale Price	2,325.00
	Bid Card # 1002	
76	MONROE 12 Ft. Sander	
	Invoice Sale Price	32.50
	Bid Card # 1072	
77	MONROE 12 Ft. Sander	
	Invoice Sale Price	35.00
	Bid Card # 1074	
78	SANBORN 5HP Gas Engine Air Compressor	
	Invoice Sale Price	220.00
	Bid Card # 1075	
79	BISHAM 931-A Tire Machine	
	Invoice Sale Price	65.00
	Bid Card # 1017	
80	PHOENIX 40-40A Balancer/Tire Machine	
	Invoice Sale Price	500.00
	Bid Card # 1080	
	CO Expense - Commission Tax	(40.78)
	CO Expense - HiBid Online Fees	(48.99)
	CO Expense - Advertising	(241.40)

Positive Balance, Monies Owed to Consignor
 Inventory Remaining For This Consignment Order

COMMISSION SETTINGS

Calculate Commission By: Each
 Commission Structure Type: Sliding Scale

Up to \$999.99	15%
Over \$999.99	10%

BUY BACK SETTINGS

Calculate Buy Back By: Each
 Buy Back Structure Type: Fixed

Any Amount	7.50%
------------	-------

STATE OF SOUTH DAKOTA



OFFICE OF ATTORNEY GENERAL

1302 East Highway 14, Suite 1
Pierre, South Dakota 57501-8501

Phone (605) 773-3215

Fax (605) 773-4106

TTY (605) 773-6585

www.state.sd.us/atg

JASON R. RAVNSBORG
ATTORNEY GENERAL

CHARLES D. McGUIGAN
CHIEF DEPUTY ATTORNEY GENERAL

October 17, 2019

Paul Nabholz
Fall River County Commissioner
906 N. River Street
Hot Springs, SD 57747

Re: Request for Official Attorney General's Opinion

Dear Commissioner Nabholz:

You recently requested an official opinion from the Attorney General's Office regarding Fall River County's potential move to a full-time state's attorney position. The Attorney General's Office respectfully declines to issue an official opinion on this matter.

After reviewing state statutes, it appears Fall River County has three options available to resolve the issue you presented. One, Fall River County can maintain the status quo – a part-time state's attorney who also contracts with Oglala Lakota County. Two, Fall River County could seek to establish a regional prosecutor's office (allowed by SDCL 7-16-24 through 7-16-30) in conjunction with Oglala Lakota County. Finally, Fall River County could designate its state's attorney position a full-time position as allowed by SDCL 7-7-12 and 7-16-19. The last two options require action before January 1st.

I advise you to consult with State's Attorney Ahrendt for legal advice regarding the interpretation of state statutes. The Attorney General has been statutorily granted authority to supervise the various state's attorneys in South Dakota. The Attorney General has not, however, been granted the authority to command that a duly elected or appointed state's attorney take a particular course of action or adopt a specific interpretation of state law. State's Attorney Ahrendt is the individual appointed by the Fall River County Commission to give legal advice to the Commission, and he can take appropriate steps to arrange alternate counsel if a conflict of interest exists.

I have copied State's Attorney Ahrendt on this letter, and I have enclosed a copy of your opinion request for his reference.

Thank you for contacting the Attorney General's Office. Please don't hesitate to contact me if you wish to discuss this matter further.

Sincerely,

A handwritten signature in black ink, appearing to read "S.R. Blair", with a long horizontal flourish extending to the right.

Steven R. Blair
Assistant Attorney General

Enclosure

CC/encl: Brian Ahrendt – Fall River County State's Attorney

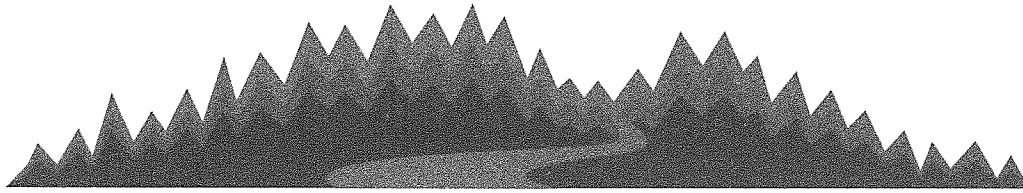

Black Hills Regional Multiple Use Coalition

P.O. Box 9496 • Rapid City, SD 57709 • 605-341-0875 • Fax 605-341-8651

October 21, 2019

TO: BOARD OF DIRECTORS

SUBJECT: MEETING NOTICE

The next Black Hills Regional Multiple Use Coalition, Board of Directors meeting will be October 25th at 4:00 pm at the Spearfish Holiday Inn.

The tentative agenda items are:

- OHV Discussion
 - o September field trip
 - o updates
- November Officer Elections
- Donations from BHRMUC
- Directors' Round Robin

Please feel free to call me at 605-341-0875 if you have any questions or comments.

Ben Wudtke
Executive Secretary



SOUTH DAKOTA DEPARTMENT OF AGRICULTURE

RESOURCE CONSERVATION AND FORESTRY DIVISION

3305 West South Street
Rapid City, SD 57702-8160
Phone: 605.394.2395 Fax: 605.394.2549
sdda.sd.gov

October 25, 2019

The South Dakota Department of Agriculture, Resource Conservation & Forestry Division is seeking public comments for the 2020 revision of the South Dakota Forest Action Plan. The Forest Action Plan is made up of five sections including the Assessment of Forest Resources, Priority Area Determination, the Forest Legacy Assessment of Need, the Forest Resource Strategy, and appendices. The Forest Action Plan will help to guide forest management actions and resource allocation for the State of South Dakota for the next ten years.

The Forest Action Plan considers all forest ownerships, including state, private, federal, and tribal forest lands. Our forests include the Black Hills forests, riparian (river bottom) forests, windbreaks and shelterbelts, urban and community forests, as well as upland (hardwood) forests such as Sica Hollow State Park.

Your input into this plan is important to us. Please visit our website at sdda.sd.gov/conservation-forestry and navigate to the "South Dakota 2020 Forest Action Plan for Public Comment" section to review these documents. A physical copy of the documents can be obtained by contacting Marcus Warnke by phone at 605.394.2395 or by using the contact information listed below.

Comments are due by December 5, 2019 and may be submitted via email to Marcus.Warnke@state.sd.us or by mail to Forest Action Plan Comments c/o Marcus Warnke, 3305 West South Street, Rapid City, SD, 57702.

Thank you in advance for providing this valuable information for the South Dakota Forest Action Plan.

Sincerely,

A handwritten signature in black ink, appearing to read "Gregory J. Josten".

Gregory J. Josten
State Forester