

## FALL RIVER COUNTY UNAPPROVED MINUTES OF APRIL 7, 2020

The Fall River Board of County Commissioners met in regular session on April 7, 2020. Present: Joe Allen, Joe Falkenburg, Heath Greenough, Paul Nabholz, Deb Russell and Sue Ganje, Auditor.

The Pledge of Allegiance was given, and the meeting called to order at 9:00 a.m.

The agenda was reviewed for conflicts; none were noted. ALL MOTIONS RECORDED IN THESE MINUTES WERE PASSED BY UNANIMOUS VOTE, UNLESS OTHERWISE STATED. The full context of the meeting can be found on the county website under Commissioners at <http://fallriver.sdcounties.org>, or under Fall River County Commission, SD at <http://www.YouTube.com>.

Motion made by Nabholz, seconded by Russell, to approve the agenda as written.

Motion made by Greenough, seconded by Russell, to approve the minutes of March 17, 2020.

Motion made by Greenough, seconded by Nabholz, to approve the minutes of March 27, 2020, which includes one correction.

Motion made by Nabholz, seconded by Greenough, to approve the General Fund transfer to Domestic Abuse in the amount of \$4,600.00, as budgeted.

Motion made by Greenough, seconded by Allen, to approve the contracts for Qualified Mental Health Provider services for Shauna R. Smith, Alison Ritterbush and Kimberly McNamara and authorize the chairman to sign.

Motion made by Greenough, seconded by Allen, to approve a pay raise for Anthony Otteson (jailer), \$14.50 to \$15.50 per hour (2080 hours), effective March 15, 2020, as per union contract.

Motion made by Greenough, seconded by Nabholz, to approve a pay raise for Patty Caster (Director of Equalization), 6-month review, \$15.00 to \$16.00 per hour, as per union contract.

Motion made by Russell, seconded by Allen, to surplus to junk a computer tower, IT, #01975.

No applications for county assistance or death expenses were presented to the board.

Susie Hayes, Director of Equalization, met with the board to discuss the 2004 and 2007 Durango's that are currently being used for field work, including needed repairs, costs and high mileage. Hayes is asking the board to consider purchase of newer 4x4 vehicles and noted budget surplus this year due to cancellation of conferences. The board recommended Hayes look at State Surplus, as well as other options, and bring back to the next meeting. Hayes also presented a projected work plan for 2020.

Discussion was held on recommendations by the Department of Revenue on holding the

appeal board hearing, which is set for the April 21, 2020 meeting, with the current COVID-19 restrictions. Modifications will include appellants only meeting in person or via phone; possible consolidated board members meeting via phone; limiting room participants to 10 people and disinfecting between in-person appellants.

Falkenburg presented a request to increase part time weed sprayer wages by \$.50 each. Motion made by Allen, seconded by Russell, to approve pay raises for Ray Palmer, from \$12.50 to \$13.00 per hour, and Ken Oechsle, from \$10.50 to \$11.00 per hour.

Frank Maynard, Emergency Management, met with the board via telephone. Motion made by Greenough, seconded by Nabholz, to approve the L.E.M.P.G. quarterly report and authorize the chairman to sign.

Maynard updated the board on personal protective equipment he has received for the jail, Sheriff's department, and ambulance services in the county. He is currently unable to obtain disposable gowns and powered air purifying respirators. He has been participating in conference calls with the Department of Health, CDC and OEM, with several meetings occurring thru Skype. Maynard also provides information, thru Skype meetings, to the State OEM office. Maynard provided a list of items on the 2020 Homeland Security grant application and reported on fires and incidents.

Tim Cox and Kelli Rhoe, Treasurer, met with the board. Motion made by Allen, seconded by Greenough, to approve the real estate tax payment plan for Timothy Cox, parcel #'s 75250-00600-00700, 75250-00600-00400 and 75250-00600-00600, in the amount of \$200.00 per month, with an approximate pay off date of July 2023 for parcel #75250-00600-00700. Motion carries by roll call vote.

Rhoe spoke to the board about an investment proposal. Motion made by Nabholz, seconded by Greenough, to allow the treasurer to name additional 2020 county banks or credit unions if she chooses to sell treasuries and purchase higher yielding CDs in those South Dakota institutions.

Sue Ganje, Auditor, met with the board to discuss the upcoming election, and how to handle early and election day voting. Ganje is encouraging absentee voting through the mail. If an individual is unable to provide the requirements for an absentee ballot (request forms require either a copy of a photo ID, or must be notarized) Attorney General Jason Ravnsborg has given authorization for voters to use their cell phone to take a picture of an authorized picture id, and email or text it to the office. There are still unknowns, but every step will be taken to help voters and make voting as easy as possible. Additional costs will be accrued, such as possible postage on return envelopes, and plexiglass. Polling places will be following the 10 people per room and distancing recommendations.

Motion made by Allen, seconded by Russell, to approve the abatement for the City of Hot Springs, Cold Springs Addition Lots 1 & 2, Block 10, tax year 2006, in the amount of \$214.68; and also removal of all penalties and interest on the remaining balance of \$644.06. Reason: The board agreed the property should be exempt.

Commissioner Nabholz discussed the corona virus, worldwide death rates dropping, and costs of shut down versus the virus. Statistics were given on loss of life by the flu, AIDS and abortion.

Nabholz also reported on discussion with Wade Huntington, Region 1 Public Health Manager on employees and customers safety measures, along with noting preparedness for the virus in Sioux Falls. The Chilson Bridge and an estimate from Brosz Engineers for replacing bridge with a bypass at less cost was discussed. Motion made by Nabholz to pay Brosz Engineering for the estimated cost of the at-grade in-location bypass with enough detail to indicate surfacing gravel vs. blotter and design speeds 25 – 55 mph. Motion dies for a lack of a second.

The Senate Bill 169 was signed by the Governor. Nabholz noted enhanced carry training will be available once the corona concern is past, and the Hydrology Conference has been cancelled for the year.

Randy Seiler, Highway Superintendent, met with the board. Motion made by Allen, seconded by Russell, to approve the Agreement for Voluntary Right of Way Donation, project no BRO8024 (14), PCN02E8, between the County and James Miller.

Motion made by Russell, seconded by Greenough, to approve the utility Right-Of-Way Certificate, project no. BRO 8024 (14), Fall River County, PCN 02E8.

Motion made by Russell, seconded by Allen, to approve the Work Order for Consultant Services, #BI-20-20 – Fall River County Wide Bridge Inspections. With Nabholz voting no, all others voting yes, motion carries.

The board requested a review of the report after bridge inspections are done.

Fuel quotes were presented as follows:

4-6-20	8,000 gallons E-10 unleaded gas
PJ's Hi-D-Way	No Bid
MG Oil	\$0.96805/gallon
Nelson's	\$1.03/gallon

Motion made by Greenough, seconded by Nabholz, to approve the low bid from MG Oil at \$0.96805 per gallon for 8,000 gallons of unleaded gas, for a total amount of \$7,744.40.

Seiler spoke that on the next agenda he will have a request to purchase off Oglala Lakota's gravel bid for 3/4" Asphalt Aggregate Blended Base Course. Those bids will be opened on April 8, 2020. Discussion was held on roads, culverts that caved in north of Edgemont, purchasing more culverts in the future, and losing another employee.

Motion made by Greenough, seconded by Russell, to approve the bills as follows:

**GENERAL FUND**

FIDELITY SEC. LIFE INS CO

EYE INSURANCE

\$157.24

AMERICAN FAMILY ASSURANCE	AMERICAN FAMILY ASSURANCE	\$590.66
CURA HOSPITALITY	INMATE FODD/SUPPLY	\$23,920.78
BEESELEY LAW OFFICE	CAAF	\$5,573.00
BRUMBAUGH & QUANDAHL,P.C.	GARNISHMENT	\$36.36
BLACK HILLS ENERGY	UTILITY POWER ELECTRIC	\$3,534.12
BOMGAARS	SUPPLY	\$23.95
BOSTON MUTUAL LIFE INS CO	LIFE INSURANCE	\$32.76
BUILDER'S FIRST SOURCE	SUPPLY	\$182.92
CAMERON, GEORGE	COURT REPORTER	\$224.20
CHARM-TEX, INC.	SUPPLY ELECTRIC	\$67.90
COOK-HUBER, KERRI	MI	\$60.00
CREDIT COLLECTIONS BUREAU	COLLECTIONS	\$32.81
DELTA DENTAL PLAN OF SD	DELTA DENTAL	\$2,510.70
EFTPS	EFTPS PAYROLL TAXES	\$32,750.26
ERTZ, DEWEY	MI	\$150.00
EXECUTIVE MGMT FINANCE	BIT NETWORK FEES	\$125.00
FALKENBURG, JOE	MILEAGE REIMBURSEMENT	\$174.72
FALL RIVER HEALTH SERVICES	INMATE & VITICM ASST	\$563.35
FARRELL, FARRELL & GINSBACH	CAAF	\$5,321.13
FITZGERALD LAW FIRM	CAAF	\$6,216.20
FALL RIVER COUNTY HERALD	PUBLICATION	\$598.89
FR COUNTY TREASURER	FIRST INTERSTATE	\$199.40
GALLS	UNIFORMS	\$95.56
GOFF, GARLAND LEE	MENTAL ILLNESS	\$3,001.00
GOLDEN WEST TECHNOLOGIES	SERVICE/NETWORK/SERVER	\$5,026.17
HEAVY HIGHWAY FRINGS	INSURANCE FEES	\$585.00
HOT SPRINGS ACE HARDWARE	SUPPLY	\$265.21
HOT SPRINGS AMBULANCE	AMBULANCE SERVICE	\$1,423.96
CITY OF HOT SPRINGS	1ST QTR. FIRE SPRINK	\$24.00
IOWA LABORERS DISTRICT	HEALTH INSURANCE	\$19,095.00
KATTERHAGEN, MARK	MENTAL ILLNESS BOARD	\$18.00
KENNEDY PIER & KNOFF LLP	MI	\$158.20
LIUNA LABORERS LOCAL 620	UNION DUES	\$300.00
LEWNO, LUCY	MENTAL ILLNESS BOARD	\$116.50
LIGHT & SIREN	EQUIPMENT	\$6,107.02
LOCKWOOD, DARCY	MENTAL ILLNESS	\$18.00
LUTHER, BRANDON	WITNESS FEE	\$23.36
LYNN'S DAKOTAMART	INMATE SUPPLY	\$12.36
MARCO	COPIER LEASE	\$339.70
MOWER, BRENDA	BLOOD DRAW	\$75.00
NATIONWIDE RETIREMENT SOL	NATIONWIDE RETIREMENT	\$29.42
NEW YORK LIFE INSURANCE	NEW YORK LIFE INSURANCE	\$65.00
NORTON, TINA	CONTRACT NURSE INMATE	\$1,150.00
CHILD SUPPORT PAYMENT CNT	CHILD SUPPORT	\$655.00

OLSON'S PEST TECHNICIANS	SERVICE CONTRACT	\$350.00
O'NEILL, JUSTIN	CAAF	\$2,264.92
OTIS ELEVATOR COMPANY	2ND QTR. SERVICE CONTRACT	\$423.15
PENNINGTON COUNTY SHERIFF	INMATE TRANSPORT	\$1,890.00
PHOENIX INVESTIGATIONS	INVESTIGATIONS	\$1,180.88
PITNEY BOWES INC	POSTAGE RENTAL	\$537.48
QUILL CORPORATION	SUPPLIES	\$275.83
RADIOLOGY ASSOCIATES	INMATE MEDICAL	\$95.41
RAPID AVIONICS, INC.	AIRPLANE MAINTENANCE	\$265.00
RAPID CITY EMERG SERVICES	MI	\$636.85
RAPID CITY FIRE DEPT	INMATE MEDICAL TRANSPORT	\$259.01
RAPID CITY REGIONAL	MI HOSPITAL BILLING	\$3,339.46
ROCKY MOUNTAIN HOLDINGS	INMATE TRANSPORT	\$2,336.06
RUSHMORE COMMUNICATIONS	SERVICE	\$2,580.00
RUSHMORE OFFICE SUPPLY	SUPPLY	\$29.90
SCOVEL PSYCHOLOGICAL	MENTAL COUNSELING	\$310.00
SOUTH DAKOTA ST TREASURER	SALES TAX	\$99.71
SD DEPARTMENT OF HEALTH	BLOOD DRAW	\$760.00
SD RETIREMENT SYSTEM	SDRS CONTRIBUTION	\$15,922.66
SD SECRETARY OF STATE	VOTER LIST	\$20.00
SERVALL	RUG/UNIFORM SERVICE	\$381.71
SKINNER, MATTHEW L. PC	CAAF	\$292.50
SOUND PHYSICIANS OF WY	INMATE MEDICAL	\$290.09
SD SUPPLEMENT RETIREMENT	SDRS SUP RETIREMENT	\$1,600.00
SPITZER CONSTRUCTION INC	SNOW REMOVAL	\$900.00
SPITZER, KRISTI	TRAVEL REIMBURSEMENT	\$40.00
TWILIGHT INC	FIRST AID SUPPLY	\$634.43
UNITED WAY BLACK HILLS	UNITED WAY DONATION	\$54.99
VANGUARD APPRAISALS INC	SERVICE FEES	\$1,200.00
VERIZON WIRELESS	CELL PHONE PLAN	\$732.37
WATCHGUARD VIDEO	EQUIPMENT	\$4,995.00
WEICHMANN, CYNTHIA	COURT REPORTER	\$114.00
WENDELL'S GARAGE	MAINTENANCE	\$925.19
YANKTON CO. SHERIFF	MI	\$50.00
YANKTON CO TREASURER	MI	\$338.40
BEHRENS, DONNA	MILEAGE REIMBURSEMENT	\$22.26
WITNESS	WITNESS FEE	\$277.75
JURORS	JURY FEE	\$2,970.92
COMMISSIONERS	MARCH SALARIES	\$4,100.00
AUDITOR'S OFFICE	MARCH SALARIES	\$15,680.67
AUDITOR'S OFFICE	OVERTIME	\$69.90
TREASURER'S OFFICE	MARCH SALARIES	\$13,146.56
TREASURER'S OFFICE	OVERTIME	\$67.73
STATE'S ATTORNEY'S OFFICE	MARCH SALARIES	\$11,385.51

STATE'S ATTORNEY'S OFFICE	OVERTIME	\$221.79
MAINTENANCE	MARCH SALARIES	\$8,673.68
MAINTENANCE	OVERTIME	\$75.94
ASSESSOR	MARCH SALARIES	\$14,752.93
ASSESSOR	OVERTIME	\$75.59
REGISTER OF DEEDS	MARCH SALARIES	\$6,416.72
VETERAN'S SERVICE OFFICE	MARCH SALARIES	\$3,616.69
GIS OFFICE	MARCH SALARIES	\$3,563.48
SHERIFF	MARCH SALARIES	\$25,283.64
SHERIFF	OVERTIME	\$3,693.95
JAIL	MARCH SALARIES	\$18,786.30
JAIL	OVERTIME	\$2,351.24
CORONER	MARCH SALARIES	\$900.00
NURSE	MARCH SALARIES	\$3,433.65
NURSE	OVERTIME	\$7.70
WEED & PEST OFFICE	MARCH SALARIES	\$3,903.90
	TOTAL FOR GENERAL FUND	\$311,233.31

**COUNTY ROAD & BRIDGE**

A & B WELDING SUPPLY CO.	WELDING SUPPLIES/LEASE	\$138.41
FIDELITY SEC. LIFE INS CO	EYE INSURANCE	\$57.08
AMERICAN FAMILY ASSURANCE	AMERICAN FAMILY ASSURANCE	\$350.88
B H ELECTRIC COOP INC.	UTILITIES SMITHWICK	\$66.90
BLACK HILLS ENERGY	UTILITY POWER ELECTRIC	\$814.39
BROSZ ENGINEERING, INC.	ENGINEERING	\$8,995.00
BUILDER'S FIRST SOURCE	SUPPLY	\$1,214.11
BUTLER MACHINERY CO	SUPPLIES/REPAIR	\$814.04
DALE'S TIRE & RETREADING	TIRE PARTS/SUPPLY	\$1,502.04
DELTA DENTAL PLAN OF SD	DELTA DENTAL	\$472.15
FLOYD'S TRUCK CENTER	REPAIRS/PARTS	\$495.25
EFTPS	EFTPS PAYROLL TAXES	\$10,435.00
FALL RIVER AUTO SUPPLY	AUTO PARTS/REPAIR	\$147.36
FALL RIVER HEALTH SERVICES	RANDOM DRUG TEST	\$132.00
FORWARD DISTRIBUTING	SUPPLIES/PARTS	\$23.10
GRIMM'S PUMP SERVICE INC	SUPPLY	\$481.19
HEAVY HIGHWAY FRINGS	INSURANCE FEES	\$120.00
HOT SPRINGS ACE HARDWARE	SUPPLY	\$42.35
HOT SPRINGS AUTOMOTIVE	AUTO SUPPLY PARTS	\$419.02
RICOH USA INC	CONTRACT SERVICE	\$75.00
IOWA LABORERS DISTRICT	HEALTH INSURANCE	\$2,900.00
LIUNA LABORERS LOCAL 620	UNION DUES	\$150.00
MG OIL	INVENTORY/SUPPLY	\$690.80
NEWBERG LUMBER CO., INC.	LUMBER	\$581.04
NEWMAN TRAFFIC SIGNS	SIGNAGE	\$43.18
SAFETY KLEEN	SUPPLIES	\$124.47

SD DEPT OF TRANSPORTATION	STATE COST SHARE BRIDGE	\$2,412.60
SD RETIREMENT SYSTEM	SDRS CONTRIBUTION	\$4,781.74
TEAM LABORATORY CHEMICAL	ROAD PATCH	\$1,289.00
TWILIGHT INC	FIRST AID SUPPLY	\$27.90
WALK-N-ROLL	PARTS	\$254.36
HIGHWAY DEPARTMENT	MARCH SALARIES	\$41,689.16
HIGHWAY DEPARTMENT	OVERTIME	\$1,788.50
	TOTAL FOR COUNTY ROAD AND BRIDGE	\$83,528.02
<b>911 SURCHARGE REIMBURSEMENT</b>		
FIDELITY SEC. LIFE INS CO	EYE INSURANCE	\$29.24
AMERICAN FAMILY ASSURANCE	AMERICAN FAMILY ASSURANCE	\$67.21
CREDIT COLLECTION BUREAU	COLLECTIONS	\$302.86
DELTA DENTAL PLAN OF SD	DELTA DENTAL	\$405.20
EFTPS	EFTPS PAYROLL TAXES	\$4,017.85
FALL RIVER HEALTH SERVICES	INMATE AND VICTIM ASSISTANCE	\$187.00
HEAVY HIGHWAY FRINGE	INSURANCE FEES	\$75.00
IOWA LABORERS DISTRICT	HEALTH INSURANCE	\$1,812.50
LIUNA LABORERS LOCAL 620	UNION DUES	\$50.00
PORTFOLIO RECOVERY ASSOC.	GARNISHMENT	\$176.54
SD RETIREMENT SYSTEM	SDRS CONTRIBUTION	\$2,019.10
TWILIGHT INC	FIRST AID SUPPLY	\$128.88
VERIZON WIRELESS	CELL PHONE PLANE	\$44.36
DISPATCH	MARCH SALARIES	\$15,709.41
DISPATCH	OVERTIME	\$1,599.39
	TOTAL FOR 911 SURCHARGE REIMBURSEMENT	\$26,624.54
<b>EMERGENCY MANAGEMENT</b>		
EFTPS	EFTPS PAYROLL TAXES	\$1,356.10
GOLDEN WEST TECHNOLOGIES	SERVICE/NETWORK/SERV	\$8.50
MARCO	COPIER LEASE	\$68.10
SD RETIREMENT SYSTEM	SDRS CONTRIBUTION	\$569.22
VERIZON WIRELESS	CELL PHONE PLAN	\$136.40
FR EMERGENCY MANAGEMENT OFFICE	MARCH SALARIES	\$4,873.55
	TOTAL FOR EMERGENCY MANAGEMENT	\$7,011.87
<b>DOMESTICE ABUSE FUND</b>		
W.E.A.V.E.	2020 BUDGET ALLOTTMENT	\$4,600.00
	TOTAL FOR M & P RELIEF	\$4,600.00
<b>24/7 SOBRIETY FUND</b>		
EFTPS	EFTPS PAYROLL TAXES	\$287.86
INTOXIMETERS	24/7 SUPPLIES	\$1,250.00
SD RETIREMENT SYSTEM	SDRS CONTRIBUTION	\$47.96
24/7 OFFICE	MARCH SALARIES	\$1,891.50
	TOTAL FOR 24/7 SOBRIETY FUND	\$3,477.32
	TOTAL PAID BETWEEN 03/18/20 AND 04/7/20	\$436,475.10

Break was taken at 10:12 a.m. and meeting resumed at 10:18 a.m.

Public comment was heard from Joe Falkenburg on pulse oxygen monitoring options. Sue Ganje reported on tent and/or canopy options for early voting. Lyle Jensen reported for the Sheriff that we have 5 females and 6 males in the Fall River County Jail and 2 females in the Pennington County Jail. Kelli Rhoe, Treasurer, thanked the Board for closing the courthouse to the public and taxes and autos are processed daily.

Discussion was held on procedures while the courthouse is closed to the public and how to handle answering the intercom in the future. Compliments were given to the friendly staff throughout the courthouse.

Motion made by Russell, seconded by Allen, to enter executive session as per SDCL 1-25-2 (1) and SDCL 1-25-2 (3) for personnel and legal purposes at 10:32 a.m.

Motion made by Russell, seconded by Nabholz, to adjourn at 10:47 a.m.

/s/Joe Falkenburg  
Joe Falkenburg, Chairman  
Board of Fall River County Commissioners

ATTEST:  
/s/ Sue Ganje  
Sue Ganje, Fall River County Auditor



2727 N Plaza Dr.  
Rapid City, SD 57702

Phone 605-348-6529 Fax 605-342-1160

**Quote**

No.: **63898**

Date: **4/8/2020**

Prepared for:

Lyle Jensen (605) 890-0372  
Fall River County Auditor  
906 N River Street  
Hot Springs, SD 57747 USA

Account No.: 1889  
Phone: (605) 745-5145  
Fax: (605) 745-3530  
Job: Managed Wireless - Silver

Qty	Description	UOM	Sell	Total
<b>Managed Wireless - Silver - 1 AP</b>				
1.00	Managed Wireless - Silver - Monthly	EA	\$75.00	\$75.00
<b>One Time Setup Fee</b>				
1.00	Wireless - One Time Setup Fee	EA	\$125.00	\$125.00

Your Price:                      **\$200.00**

Total:                      **\$200.00**

Prices are firm until 4/22/2020

**Prepared by:** Eric Eisenbraun, ericeisenbraun@goldenwest.com

**Date:** 4/8/2020

Managed Wireless - Silver. Monthly. One Time Setup Fee. - Up to 3 APs for \$75 per month.

**Accepted by:**                     *[Signature]* - Auditor                    

**Date:**                     4-9-20                    

**Disclaimer**

Unless otherwise specified, all labor is charged on a time and materials basis. Any additional service charge or travel will apply.  
Any quoted cable runs assume that there is an available cable pathway; if not, additional charges may apply.  
Applicable taxes and/or additional freight charges may be added on to the invoice.  
Terms: 30% down payment required for sales of \$ 5,000.00 or more, with the balance due Net 15 days of invoicing.



2727 N Plaza Dr.  
Rapid City, SD 57702

Phone 605-348-6529 Fax 605-342-1160

**Quote**  
No.: **63899**  
Date: 4/8/2020

Prepared for:

Lyle Jensen  
Fall River County Auditor  
906 N River Street  
Hot Springs, SD 57747 USA

Account No.: 1889  
Phone: (605) 745-5145  
Fax: (605) 745-3530

Qty	Description	UOM	Sell	Total
1	Ruckus ZoneFlex T301n, 30x30 Deg, Outdoor 802.11ac 2x2:2, Narrow Beam, Dual Band Concurrent Access Point	EA	\$1,308.12	\$1,308.12
1	Ruckus Spare POE adapter with US power adapter	EA	\$60.00	\$60.00

Your Price: \$1,368.12  
Total: \$1,368.12

Prices are firm until 4/22/2020

**Prepared by:** Eric Eisenbraun, ericeisenbraun@goldenwest.com

**Date:** 4/8/2020

GWT to configure AP with hosted VSCG and either mail to customer or deliver in person. Lyle will handle the cabling and installation.

**Accepted by:** 

**Date:** 4-9-20

**Disclaimer**

Unless otherwise specified, all labor is charged on a time and materials basis. Any additional service charge or travel will apply. Any quoted cable runs assume that there is an available cable pathway; if not, additional charges may apply. Applicable taxes and/or additional freight charges may be added on to the invoice. Terms: 30% down payment required for sales of \$ 5,000.00 or more, with the balance due Net 15 days of invoicing.



WIRELESS MONITORING AND MANAGEMENT SERVICE AGREEMENT

- I. Description of Services. Golden West Technologies' Wireless Monitoring and Management Service is a comprehensive monitoring and management solution for RUCKUS Wireless appliances.
II. Setup Procedures. Golden West Technologies will configure ship and remotely assist with the onsite install of the RUCKUS Access Points. The Golden West Technologies Network Operations Center can then assist in opening a management rule for Golden West.
III. Fees. On the in-service date, the customer will be charged a one-time setup fee of \$125.00 and monthly fees based upon the table below.

Service Level Bronze [ ] Silver [x]
Monthly Cost of Service \$75.00

Coverage:
Number of Access Points Up to
3

Address of Service: Fall River County Auditor, 906 N River Street, Hot Springs, SD 57747

- IV. Term. The initial term of this Agreement is for one (1) year. Service will begin when the equipment is installed and is operational, known as the "in-service" date. Upon completion of the initial term, this agreement will automatically renew for successive thirty (30) day terms unless terminated by either party's written notice at least thirty (30) days before the end of the then-current term. If terminated, this service agreement ends on the last day of the then current term.
V. Acceptance. By signing this agreement, the Customer accepts and agrees to all of the Terms and Conditions on both sides of this agreement.
VI. Notice. Any notices required to be given by Golden West Technologies shall be sent via E-mail to lyle.jensen@frcounty.org All notices to Golden West Technologies shall be sent via E-mail to info@gwtis.com.

IN WITNESS WHEREOF, the parties have caused this Agreement to be duly executed by their authorized representatives as indicated below.

Golden West Technologies

Fall River Auditor

By: \_\_\_\_\_
(Authorized Signature)

By: [Signature] \_\_\_\_\_
(Authorized Signature)

Print Name: James Van Loan

Print Name: SAC BANJY

Title: Sales Manager

Title: Fall River Auditor

Date: \_\_\_\_\_

Date: 4-9-20

\*\*Additional fees may apply and are detailed in the Terms and Conditions on page 2 of this agreement.



## WIRELESS MONITORING AND MANAGEMENT SERVICE AGREEMENT

### Terms and Conditions:

1. The Customer has contracted with Golden West Technologies, or is about to contract with Golden West Technologies for Wireless Monitoring and Management. All monthly charges are payable in advance. The initial term of this Agreement is for one (1) year. Golden West Technologies monitoring and management services will begin when the necessary equipment and/or tools are installed and are operational, and when the necessary communications connection is completed. If terminated, this Agreement ends on the last day of the then-current term. The Customer shall be responsible for payment of all Services up to the time of suspension or termination and for payment of a late charge of one and one half percent (1 1/2 %) per month on any unpaid balances. A fee of up to 35% of the outstanding balance may be added to any account that is sent to collections due to failure to pay.
2. This Agreement may be suspended, at Golden West Technologies' option, for late payment or non-payment of services by the Customer. In the event that Golden West Technologies, in its sole discretion, determines that the Customer's network system poses an immediate risk of harm to Golden West Technologies' business or other Customers, Golden West Technologies may immediately suspend and/or terminate this Agreement. Additionally Golden West may terminate this Agreement if customer support requirements exceed expected levels. Customer will be given written notice of said termination at least thirty (30) days prior to termination, in which to bring support requests in line with expected levels.
3. The Customer may terminate this Agreement for cause after having first provided written notice of a breach of performance to Golden West Technologies and given thirty (30) days following the notice for Golden West Technologies to cure the alleged breach. In the event that the Customer terminates this Agreement, without cause, the Customer agrees to pay Golden West Technologies an amount in total equal to three times the monthly Agreement charges either through payment of actual fees or in a cash settlement or combination thereof.
4. Golden West Technologies assumes no liability for delay in installation of the system, or interruption of service due to strike, riots, floods, fires, acts of God, or any causes beyond the control of Golden West Technologies, including interruption in telephone service or internet connection. Golden West Technologies will not be required to supply service to the Customer while interruption of service due to any such cause shall continue. Golden West Technologies shall not be liable for any loss or damage caused by defect or deficiencies in the network nor shall Golden West Technologies incur any liability for any delay in response or non-response of any institutions or individuals notified by Golden West Technologies. The Customer understands that Golden West Technologies will not receive notifications when the telephone line, telephone equipment, internet connection, or other transmission mode is not operating or has been cut, interfered with, or otherwise compromised. Golden West Technologies shall not be obligated to perform any monitoring service during any time when Customer's telephone, telephone equipment, internet connection, or other transmission mode shall not be working, is disabled, or otherwise compromised by any means since signals to Golden West Technologies are received solely by means of telephone communication or internet connection.
5. GOLDEN WEST TECHNOLOGIES IS NOT RESPONSIBLE FOR ANY FAILURES, REPAIRS OR MODIFICATIONS RESULTING OR NECESSITATED BY CUSTOMER'S HARDWARE, SOFTWARE, OR OTHER SERVICES PROVIDED BY THIRD PARTIES. THE WIRELESS MONITORING AND MANAGEMENT SERVICES ARE PROVIDED ON AN "AS IS" BASIS WITHOUT FURTHER WARRANTIES, EXPRESS OR IMPLIED, INCLUDING BUT NOT LIMITED TO WARRANTIES OF MERCHANTABILITY, FITNESS FOR A PARTICULAR PURPOSE, AND ANY WARRANTIES ARISING FROM A COURSE OF DEALING, USAGE, OR TRADE PRACTICE.
6. UNDER NO CIRCUMSTANCES WILL GOLDEN WEST TECHNOLOGIES OR ITS AGENTS BE LIABLE FOR INCIDENTAL, CONSEQUENTIAL, OR PUNITIVE DAMAGES OF ANY KIND, INCLUDING BUT NOT LIMITED TO LOST REVENUE, LOST PROFITS COVER, LOSS OF DATA OR INTERRUPTION. IF THERE SHALL, NOTWITHSTANDING THE ABOVE PROVISIONS, AT ANY TIME BE OR ARISE ANY LIABILITY, ON THE PART OF GOLDEN WEST TECHNOLOGIES OR ITS AGENTS BY VIRTUE OF THIS AGREEMENT, SUCH LIABILITY IS AND SHALL BE LIMITED TO THE SUM OF SIX (6) MONTHS SERVICE FEES. SUCH LIABILITY AS HEREIN SET FORTH IS FIXED AS LIQUIDATED DAMAGES AND NOT A PENALTY AND THIS LIABILITY SHALL BE COMPLETE AND EXCLUSIVE. CUSTOMER ACKNOWLEDGES THAT IT IS IMPRACTICAL AND EXTREMELY DIFFICULT TO FIX THE ACTUAL DAMAGES, IF ANY, WHICH MAY PROXIMATELY RESULT FROM A FAILURE OF GOLDEN WEST TECHNOLOGIES OR ITS AGENTS TO PERFORM ANY OF ITS OBLIGATIONS OR A FAILURE OF THE SYSTEM TO OPERATE BECAUSE OF, AMONG OTHER THINGS: THE UNCERTAIN AMOUNT OF VALUE OF CUSTOMERS PROPERTY OR THE PROPERTY OF OTHERS WHICH MAY BE LOST OR DAMAGED; THE INABILITY TO ASCERTAIN WHAT PORTION, IF ANY, OF ANY LOSS WOULD BE PROXIMATELY CAUSED BY GOLDEN WEST TECHNOLOGIES OR ITS AGENTS FAILURE TO PERFORM ANY OF ITS OBLIGATIONS. ANY ACTION AGAINST GOLDEN WEST TECHNOLOGIES IN CONNECTION WITH ITS SERVICE, MUST BE COMMENCED WITHIN ONE YEAR AFTER THE ALLEGED ACT OF MALFEASANCE, MISFEASANCE, OR NONFEASANCE OCCURRED.
7. NO PARTY WILL BE LIABLE FOR ANY FAILURE OF PERFORMANCE, IF SUCH FAILURE IS DUE TO ANY CAUSE BEYOND SUCH PARTY'S REASONABLE CONTROL KNOWN AS FORCE MAJEURE, INCLUDING ACTS OF GOD, FIRE, EXPLOSION, VANDALISM, TERRORISM, CABLE CUT, STORM, OR OTHER SIMILAR OCCURRENCE, ANY LAW, ORDER, REGULATION, DIRECTION, ACTION, OR REQUEST BY ANY GOVERNMENT, CIVIL, OR MILITARY AUTHORITY, NATIONAL EMERGENCIES, INSURRECTIONS, RIOTS, WARS, LABOR DIFFICULTIES, SUPPLIER FAILURES, SHORTAGES, BREACHES, OR DELAYS.
8. In the event Golden West Technologies is destroyed or so substantially damaged by Force Majeure that Golden West Technologies is unable to provide the services under this Agreement, Golden West Technologies shall have a reasonable period of time in which to relocate or subcontract the Wireless monitoring and management service.
9. It is understood and agreed by and between the parties hereto, that if there is any conflict between this Agreement and customers purchase order, or any other document, this Agreement will govern.
10. The Customer may not assign this Agreement, unless the written consent of Golden West Technologies is first obtained.
11. This Agreement shall be governed by the laws of the State of South Dakota, except its "Conflict of Laws" rules. Venue for all disputes shall be the Circuit Court for Pennington County, South Dakota. In the event Customer shall violate any term, covenant or agreement hereunder and Golden West Technologies shall incur any legal expenses as a result thereof, Customer agrees to pay reasonable attorney's fees so incurred by Golden West Technologies, including court costs and appellate proceedings.
12. All rights, powers and remedies reserved or given to Golden West Technologies hereunder shall inure to the benefit of Golden West Technologies, its successors and assigns.
13. In the event any of the terms or provisions of this Agreement shall be invalid or inoperative, all of the remaining terms and provisions shall remain in full force and effect.
14. The person executing this Agreement for and on behalf of Customer hereby warrants and represents that he/she is duly authorized to execute same and has the authority to bind and obligate Customer herein.
15. At any time after the initial term of this Agreement, Golden West Technologies may increase charges or change the terms and conditions of this Agreement upon providing 60 days' notice to the Customer. Upon receipt of the notice of increased charges or change of terms and conditions, the customer may cancel Agreement by providing notice in writing 30 days prior to the effective date of the increase or changes.
16. The Customer agrees that for so long as Golden West Technologies is engaged by the Customer, and for a period of twenty-four months thereafter, the Customer shall not, directly or indirectly, call upon, solicit, recruit, or assist others in calling upon, recruiting or soliciting any persons who is an employee of Golden West Technologies and whom the Customers has become aware of by virtue of this engagement for the purpose of having such a person work for the Customer, or for any other person firm corporation or entity.



Willoughby Industries, Inc.  
 5105 West 78th Street  
 Indianapolis, IN 46268  
 toll free (800) 428-4065  
 fax (317) 875-0837  
 www.willoughby-ind.com

# QUOTATION

## REP - LIST PRICING

**TO:**

BENNEROTTE MARKETING AGENCY  
 14332 21ST AVE N SUITE 100  
 PLYMOUTH, MN 55447  
 US

**JOB NAME:**

FALL RIVER COUNTY JAIL  
 HOT SPRINGS, SD  
 US

ATTN: ERIC VAN DEN HEUVEL

Project No: 5143

Quote No.	Date	Cust No.	Delivery	F.O.B.	Terms	Expiration
2001020	4/6/2020	BENN23	14-16 WEEKS ARO & SUB	INDIANAPOLIS	1% 10 N 20DAYS	30 DAYS
Quantity	UM	Model	Description	Price \$	Extension \$	
<b>TAG01: REPLACEMENT COMBI</b>						
1	EA	ECW-1546-350-RPF-C-OF	15" SECURITY COMBINATION UNIT, REPLACEMENT, WALL OUTLET, WALL MOUNTED (Replacement for Super Secur A350)			
1	EA	BPH	LIGATURE-RESISTANT BUBBLER/FILLER			
1	EA	3.5GPF	3.5 GALLONS PER FLUSH BOWL			
1	EA	NV	NO VALVE			
1	EA	CW2	COMBINED WASTE WITH CLEANOUT (COMBI)			
1	EA	GWC	GASKETED TOILET WASTE CONNECTION			
				<del>2,482.00</del>	<del>2,482.00</del>	
<b>TAG02: SELF-CLOSING CARTRIDGE</b>						
1	EA	600276 A	CARTRIDGE SELF-CLOSING #77261 >>>> Not to be sold in CA <<<<< MAXIMUM DISCOUNT 20% (.80 MULTIPLIER)			
				<del>89.06</del>	<del>89.06</del>	
<b>Total for Quote \$</b>						<del>2,571.06</del>

\$ 1700<sup>00</sup>

\$ 65<sup>00</sup>

+ 150 Fat

DELIVERY LEAD TIMES ARE APPROXIMATE AND ARE BASED ON MANUFACTURING TIMELINES IN PLACE AT TIME OF QUOTE. PLEASE CHECK WITH FACTORY AT TIME OF ORDER FOR CURRENT DELIVERY LEAD TIMES. PRICES GOOD FOR 30 DAYS. SUBJECT TO TERMS & CONDITIONS. WILLOUGHBY BIDS THIS PROJECT AS CLOSE AN EQUAL AS POSSIBLE. GOODS OF U.S. ORIGIN. QUOTED IN U.S. DOLLARS. WILLOUGHBY PRODUCTS ARE MADE IN THE USA! ABOVE QUANTITIES ARE ESTIMATES ONLY. VERIFY ALL QUANTITIES BEFORE ORDERING. IF LIFTGATE DELIVERY IS REQUIRED, ORDER IS SUBJECT TO ADDITIONAL FREIGHT COSTS.

\*WARNING: Cancer and Reproductive Harm - www.P65Warnings.ca.gov \*California P65 product/package warning label required\*

# MODEL NUMBER AND OPTIONS:

**1.) Base Model Number:**

- ECW-1546-350-RPF Wall Mounted, Wall Outlet, Replacement Combination for Super Secur A-350

**2.) Toilet Orientation:**

- C Centered

**3.) Fixture Mounting:**

- OF Off-Floor

**4.) Bubbler Selection:**

- BPH Ligature-resistant Bubbler/Filler (Standard)
- BC Code Bubbler/Filler (w/ Mouth Guard)
- FLH Ligature-resistant Lav. Filler

**5.) Flush Valve GPF'S (Must Specify):**

- 1.28 GPF HET (4.8 Lpf) (WaterSense Labeled)
- 1.6 GPF ULF (6.0 Lpf)
- 3.5 GPF (13.2 Lpf)

**6.) Lavatory Valve Selection:**

- NV No Valve
- PSL1 Single Temp. Pneumatic Non-metering
- PSL2 Dual Temp. Pneumatic Non-metering
- PML1 Single Temp. Pneumatic Metering
- PML2 Dual Temp. Pneumatic Metering
- E1L1 Single Temp. Electronic (Pick Control)\*
- E1L2 Dual Temp. Electronic (Pick Control)\*

**Valve Manifold Options:**

Pneumatic or Electronic Only:

- MA2  MA3  MA4

**7.) Lavatory Valve Actuation:**

- PBH Ligature-resistant Push Buttons
- PZPB Ligature-resistant Piezo Piezo Push Buttons\*

**8.) Electronic Controls\***

(Must Use Electronic Lavatory & Flush Valves):

- WUCC-3010  Pneumatic  WMSII

**9.) Lavatory Waste:**

- OV Lavatory Overflow
- CW1 Combined Waste w/o Clean-out
- CW2 Combined Waste w/ Clean-out (Standard)
- LW1 Thru-Wall Extension, 'P' Trap
- LW2 Thru-Wall Extension & Clean-Out
- SLOW Slow Drain

**10.) Toilet Waste:**

- TWE Toilet Waste Extension
- TW3 3" Clean-Out for (TWE)
- TW5 4" Clean-Out for (TWE)
- PC3 Pinned Clean-Out Plug PVC-3"
- PCB3 Pinned Clean-Out Plug Brass-3"
- PC4 Pinned Clean-Out Plug PVC-4"
- PCB4 Pinned Clean-Out Plug Brass-4"
- GWC Gasketed Waste Connection (Standard)

**11.) Toilet Waste Coupling For (TWE):**

- TWC3P Connecting to 3" PVC
- TWC3C Connecting to 3" Cast Iron
- TWC4P Connecting to 4" PVC
- TWC4C Connecting to 4" Cast Iron

**12.) Options**

- T4 Manual Reset Toilet Overflow Preventer, Req.(FV)
- T4A Auto Reset Toilet Overflow Preventer, Req. (FV)
- ET4 Electronic Toilet Overflow Preventer, Requires (EFV) & (WUCC-3010) or (WMSII)\*
- FV Hydraulic Flush Valve (Includes Push Button)
- EFV Electronic Flush Valve (Pick Control)\*
- EFVP Electronic Flush Valve w/ (PZPB) (Pick Control)\*
- TFE Toilet Flush Extension
- FVT Flush Valve Connection
- HS Hinged White Plastic Seat (No Cover, not recommended for Maximum Security/Ligature-resistant use)
- RTH \_\_\_\_\_ Recessed Tissue Holder
  - L  LF  C  RF  R
- TB1 \_\_\_\_\_ Single Toothbrush Holder
  - L  R
- TB2 \_\_\_\_\_ Dual Toothbrush Holder
  - L  R
- TH1 \_\_\_\_\_ Single Towel Hook
  - L  LF  C  RF  R
- TH2 \_\_\_\_\_ Dual Towel Hook
  - L  LF  C  RF  R
- DC Decorator Color (Fixture exterior only - White)
- TF24H Hard-wired Transformer, 110VAC to 24VAC\*
- TF24P Plug-in Transformer, 110VAC to 24VAC\*
- HPS High Polish Seat
- VG Vent Grille, 6-1/2" x 9-1/2" (13-3/4 in<sup>2</sup> free area)
  - L  LF  RF  R
- TG 12 Gauge Cabinet
- TSC Toilet Shipping Cover
- Other \_\_\_\_\_
- Other \_\_\_\_\_

\*(Req. 110V power through ground fault interrupter (GFCI) receptacle)

Approved For Manufacturing By: Lyle Jensen Date: 4/3/2020 Company: Fall River County  
 Wall Thickness: 8" Wall Type: Concrete

VERIFY ALL DIMENSIONS WITH FACTORY PRIOR TO ROUGH-IN  
 WILLOUGHBY RESERVES THE RIGHT TO MAKE CHANGES IN DESIGN AND DIMENSIONS WITHOUT FORMAL NOTICE AND WITHOUT INCURRING OBLIGATION.

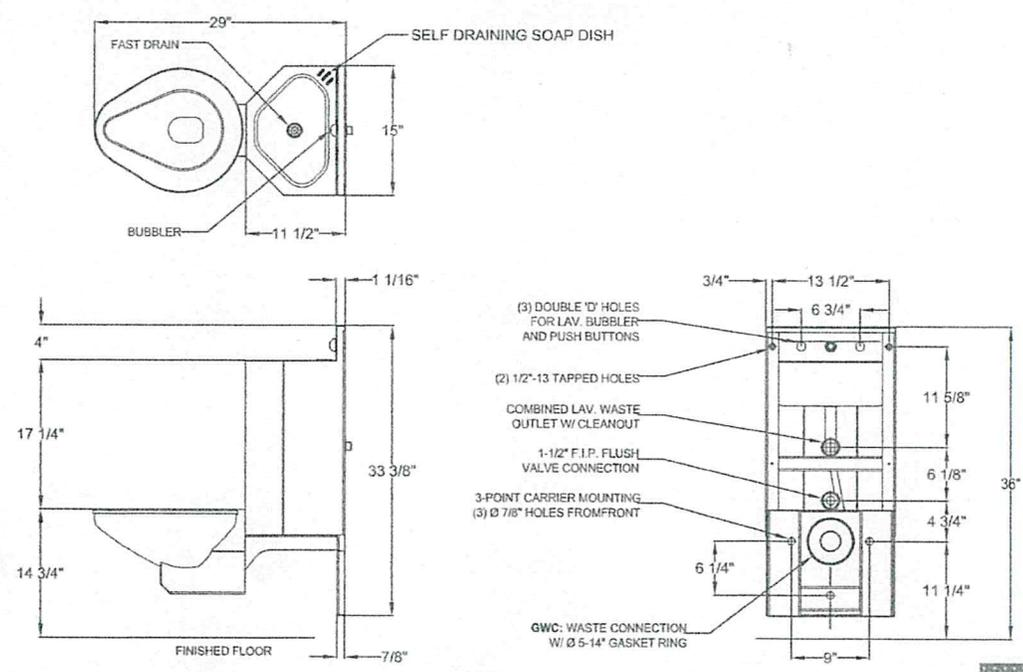

visit our website at [www.willoughby-ind.com](http://www.willoughby-ind.com)  
 5105 West 78th Street • Indianapolis, IN. 46268  
 (317) 875-0830 • Fax: (317) 875-0837 • (800) 428-4065



MADE IN THE U.S.A.



## ECW-1546-350-RPF Wall Mounted Wall Outlet Replacement Combination For Super Secur A-350

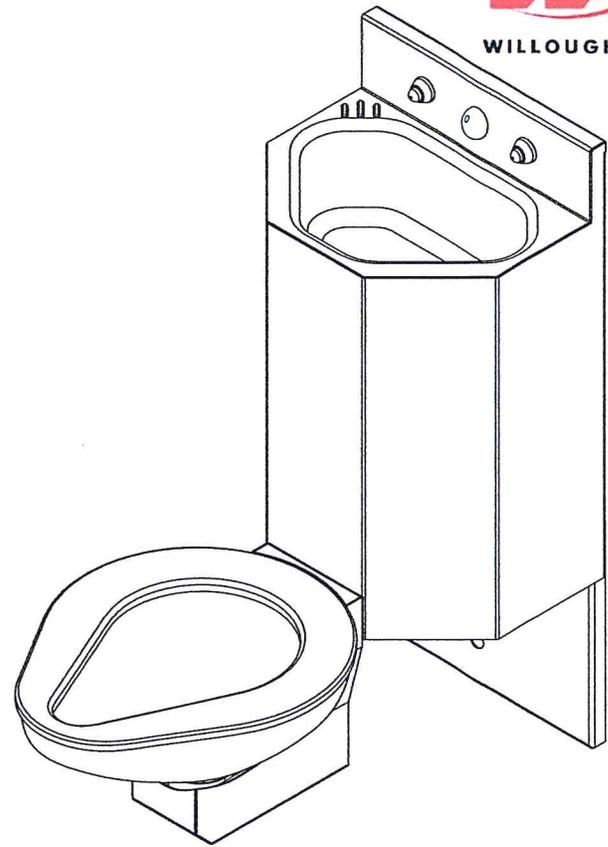
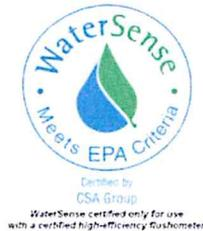

### Recommended Specifications

*(Unit may be shown with optional features)*

Wall Mounted, Wall Outlet, Replacement Combination lavatory/toilet (for Super Secur A-350) shall be:  
Willoughby Model No. **ECW-1546-350-RPF**  
(Designed to replace the discontinued **Super Secur A-350**)

Fixture shall be fabricated from 14 GA, Type 304 stainless steel. The construction shall be all welded, with exposed stainless surfaces polished to a #3 satin finish.

Standard toilet shall include: elongated toilet bowl with contoured seat, integral crevice-free self-draining flushing rim with positive afterfill and fully enclosed 2-3/8" O.D. trap which shall maintain a minimum 2" seal and pass a 2" ball. Toilet shall be blowout type which requires 35 psi minimum flushing pressure.

Standard lavatory shall include: multi-sided shaped bowl, 12-3/4" x 8-3/4" x 5" deep, stainless steel penal filler/bubbler, fast drain with air vent, combined waste w/ cleanout\*\* and self-draining soap dish.

Fixture shall withstand loadings up to 2,000 lbs. with no measurable deflection and loadings up to 5,000 lbs. with no permanent damage.

Cabinet interior shall be sound deadened with fire-resistant material.

Anchoring hardware by others. Unit shall require chase area for installation and maintenance.

***On back to back fixture installations, do not use standard cross type waste fitting: cross flow may result due to blowout jet action. Use sanitary or offset type waste fittings.***

**Note:** Unit will pass a 2" ball.

**Note:** Fixture should only be used with a listed high-efficiency flushometer to ensure the complete system meets the requirements of WaterSense.

**\*\* Check applicable plumbing code for acceptability.**



**WARNING:** Cancer and Reproductive Harm

- [www.P65Warnings.ca.gov](http://www.P65Warnings.ca.gov)



MADE IN THE U.S.A.

visit our website at [www.willoughby-ind.com](http://www.willoughby-ind.com)  
5105 West 78th Street • Indianapolis, IN. 46268  
(317) 875-0830 • Fax: (317) 875-0837 • (800) 428-4065

# Estimate

Straight Line Striping  
 1713 Space Court  
 Rapid City, SD 57701  
 Cell 605-381 4940  
 Home 605-341-0863  
 Dan St.Pierre

Name/Address
Fall River Courthouse 906 Morris River Rd. Hot Springs, SD 57747

Date	Estimate No.	Work Order #
04/19/20	310	

Item	Description	Quantity	Cost	Total
Handicap	Handicap Emblem	6	30.00	180.00T
Poles	Poles Blue HCP	4	7.00	28.00T
4" yellow	4"Yellow Stripe	2,519	0.14	352.66T
Blowing Parking	Blowing Parking Lot For Striping Area	1	75.00	75.00T
Trip Charge	Trip Charge	1	100.00	100.00T
	Sales Tax		2.00%	14.71
ESTIMATE IS GOOD FOR 30 DAYS			Total	\$750.37

# Estimate

Straight Line Striping  
 1713 Space Court  
 Rapid City, SD 57701  
 Cell 605-381 4940  
 Home 605-341-0863  
 Dan St.Pierre

Name/Address
Fall River County Weed & Pest 1029 N. River St. Hot Springs, SD 57747

Date	Estimate No.	Work Order #
04/19/20	767	

Item	Description	Quantity	Cost	Total
Description	1 - HCP 540 Ft Yellow Set Parking	1	225.00	225.00T
Blowing Parking	Blowing Parking Lot For Stripping Area	1	40.00	40.00T
	Sales Tax		2.00%	5.30
ESTIMATE IS GOOD FOR 30 DAYS			Total	\$270.30

Lyle Jensen and Patty Caster went to look at these vehicles at SD Federal Surplus on Wednesday April 15.

The following is the information important to purchase. Both vehicles are on hold until April 22.

Both vehicles were bought from GSA (Government Surplus Auction) in Colorado and neither one appears to have been in law enforcement service.

The 2010 came from Aurora and the 2013 from Commerce.

The 2010 has good ground clearance, traction control and a receiver hitch already installed.

The tires are good for the terrain this office travels over and have an estimated 15 to 20 thousand miles left on them.

It is a little smaller than the 2013, has some peeling paint issues on the grill and roof top and the weather stripping around the doors would need to be glued and or replaced.

The 2013 is in like new condition. The plastic front end is all intact, so it appears as if it has only highway miles on it.

The ground clearance isn't as high as the 2010, and it also has traction control.

The tires appear to be the originals so they could possibly need replaced in the near future. Also, they may need upgraded to handle the terrain we travel.

The weather stripping around the doors would need to be glued.

Both are vehicles that could serve this office well into the future.

If we do purchase one of these vehicles, we would still need to make repairs on one of the Durangos to get it back on the road. The 2004 needs the least repairs at this time. As submitted to you previously, the struts would need to be replaced at an estimated cost of \$550, which can be paid for through the DOE vehicle maintenance budget. The transmission is a concern and when it fails, the question will be to put the added funds into repairing it, which is not in the DOE budget or replacing it with another vehicle.

Due to the annual Department of Revenue schools and the SDAAO conference being cancelled because of COVID-19, the Equalization budget could use the funds allotted to put towards the purchase of the 2010 Ford Explorer. This amount would be \$5,850.



2010 Ford Explorer 4x4, 66,346 miles, silver. 6 cylinder, 4.0 liter, gas. Has power windows, locks, cruise control, A/C, 2 keys and fobs.

**Stock #:** 001-F4253

**Location:** Western Distrib. Site

**Price:** 9,500.00

**Unit of Measure:** EA

**SN VIN:** 1FMEU7DE6AUA24253



2013 Ford Explorer 4x4, 66,707 miles, blue. 6 cylinder, 3.5 liter, flex fuel. 7 passenger, has power windows, locks, cruise control, front and rear A/C, and 2 keys with fobs.

**Stock #:** 906-A2743

**Location:** Western Distrib. Site

**Price:** 14,300.00

**Unit of Measure:** EA

**SN VIN:** 1FM5K8B9DGC92743

## DOE VEHICLE STATUS

Both of these vehicles are retired patrol units that were well used when issued to the Equalization office in 2014.

### 2007 White Durango

Mileage as of 2/11/2020      154,757                      oil change on this date

Windshield is badly cracked and needs to be replaced -	estimated cost of \$ 260
Air conditioner needs repair (will not hold charge) -	estimated cost of \$ 500 – 1,000
Replace struts (not safe to drive right now) -	estimated cost of \$ 550
Transmission is questionable	estimated cost of \$ 2,500 rebuilt

### 2004 Black Durango

Mileage as of 2/11/2020      147,288                      oil change on this date

Replace struts (not safe to drive right now) -	estimated cost of \$ 550
Transmission is very questionable -	estimated cost of \$ 2,500 rebuilt

### **NEEDS:**

The Director of Equalization office requires 2 reliable vehicles available at all times.

- We do our assessing field work in teams of two, and with our rotation schedule, have two teams out at a time.
- Each vehicle needs to have 4-wheel drive capabilities. We travel on rough and remote roads at times and cannot take the chance to be stranded with a broken-down vehicle and little or no cell phone coverage to call for assistance.
- If we invest in a decent vehicle(s) for the DOE office, it(they) would last us a very long time.
- Depending on the time of year, our vehicles are shared with GIS also.

### **CONSIDERATIONS:**

- Paying for repairs now only delays the need for replacement vehicles for an unknown amount of time
- We will have a budget surplus this year due to cancelled education travel due to COVID-19.
- This will be a budget item to plan ahead for or surplus for, no matter when it happens
- COVID-19 will not reduce or eliminate the need for vehicles this year, we will still need to drive to properties, whether for physical inspections or drive-by inspections.

4/14/20 FALL RIVER COUNTY		7 YEAR BUDGET HISTORY						DIR. OF EQUAL. (FR)	LPBUD7	PAGE 1
ACCOUNT DESCRIPTION	GL#	14 ACTUAL	15 ACTUAL	16 ACTUAL	17 ACTUAL	18 ACTUAL	19 ACTUAL	20 BUDGET	21 REQUESTED	21 APPROVED
4110.162 D.O.E. SAL	10100X4110162	141,062.64	154,899.79	144,053.81	149,431.40	152,377.83	165,559.17	175,710.00	.00	
4120.162 DIR OF EQUAL SOC SEC	10100X4120162	10,771.86	11,849.83	11,020.12	10,894.34	10,788.19	11,944.39	13,445.00	.00	
4130.162 D.O.E. RETIREMENT	10100X4130162	6,715.04	7,647.24	7,671.55	8,965.93	9,092.06	9,880.71	10,545.00	.00	
4140.162 WORKMAN'S COMP	10100X4140162	2,257.30	1,820.89	2,230.73	2,383.06	1,865.65	2,102.45	1,900.00	.00	
4150.162 D.O.E.HEALTH INS	10100X4150162	21,903.24	12,153.87	11,355.00	12,619.50	13,578.50	15,078.50	18,195.00	.00	
BLUE CROSS DEDUCTIBLE	10100X4151162	1,500.00	.00	.00	.00	.00	.00	.00	.00	
4160.162 UNEMPLOYMENT	10100X4160162	.00	.00	2,360.00	4,896.00	.00	.00	.00	.00	
4180.162 D.O.E.DENTAL INS	10100X4180162	1,791.75	1,416.60	1,294.40	1,456.20	1,537.10	1,820.25	1,945.00	.00	
ACCOUNT TYPE TOTALS	41	186,001.83	189,788.22	179,985.61	190,646.43	189,239.33	206,385.47	221,740.00	.00	
4210.162 INSURANCE	10100X4210162	854.81	1,050.67	508.98	630.89	482.48	467.82	600.00	.00	
4220.162 APPRAISAL & FIELD WOR	10100X4220162	474.19	600.75	8,241.31	.00	490.40	47.96	600.00	.00	
4230.162 D.O.E. PUBLISHING	10100X4230162	615.12	668.22	603.35	704.18	763.86	1,051.34	800.00	.00	
4241.162 POSTAGE LEASE	10100X4241162	686.40	2,768.04	3,038.81	453.08	474.08	120.27	.00	.00	
4260.162 D.O.E. SUPPLIES	10100X4260162	6,216.30	2,337.13	1,125.64	1,457.36	1,842.70	1,233.19	1,500.00	.00	
APPRAISAL SUPPLIES (NOT USED)	10100X4261162	142.40	.00	.00	.00	.00	.00	.00	.00	
4263.162 D.O.E. COPIER LEASE	10100X4263162	3,228.29	3,599.18	2,819.82	2,728.59	2,743.33	2,913.93	3,000.00	.00	
4265.162 POSTAGE SUPPLY	10100X4265162	.00	.00	373.45	2,114.55	2,364.99	2,400.35	2,600.00	.00	
4270.162 D.O.E. TRAVEL & EDUCA	10100X4270162	5,661.78	4,957.00	5,028.17	5,016.33	5,513.42	4,526.93	9,115.00	.00	
4272.162 D.O.E. CAR MAINTENANC	10100X4272162	555.50	922.86	198.00	1,111.17	252.93	.00	1,000.00	.00	
4280.162 D.O.E. PHONE	10100X4280162	2,298.21	3,090.37	3,850.98	5,103.45	4,195.21	1,309.76	1,500.00	.00	
ACCOUNT TYPE TOTALS	42	20,733.00	19,994.22	25,788.51	19,319.60	19,123.40	14,071.55	20,715.00	.00	
4340.162 D.O.E. OFFICE EQUIP &	10100X4340162	9,269.29	14,439.04	12,433.88	11,347.09	12,254.96	14,103.45	15,000.00	.00	
ACCOUNT TYPE TOTALS	43	9,269.29	14,439.04	12,433.88	11,347.09	12,254.96	14,103.45	15,000.00	.00	
FUND TOTALS	10100	216,004.12	224,221.48	218,208.00	221,313.12	220,617.69	234,560.47	257,455.00	.00	
<i>Final</i> DEPT TOTALS	162	216,004.12	224,221.48	218,208.00	221,313.12	220,617.69	234,560.47	257,455.00	.00	

\* = BUDGET INCLUDES TRANSFERS AND/OR SUPPLEMENTS



*Emergency Management  
Fall River County*

*Franklin W. Maynard CEM CFM  
906 N. River St.  
Hot Springs, SD 57747*

*605 745-7562 605 890-7245 frem@qwtc.net*



Date: April 21, 2020

Subj: Commission Update

1. **Honda Big Red:** Fall River Health has contacted me requesting approval to use the Honda Big Red to transport Covid 19 positive patients from the ER to the designated ward for care. The ward is located at the back of the hospital, and by utilizing the Honda, the staff would not have to take the patient through the hospital to the ward, but would transport the patient outside to the ward.
2. **Region 4 HLS Meeting:** The meeting was held via Skype and all projects were prioritized and the list was sent to the State HLS Office for review and approval.
3. **Personal Protective Equipment:** I have reordered the gowns and powered air purifying respirators, and the order has been denied by the Dept. of Health. Dr. Pete Sotherland has provided a protocol for sterilizing the ppe for reuse. The service is provided to 5 other entities within the county.
4. **Conference Calls:** I have been participating in the Dept of Health, CDC and OEM calls. Each week there are several scheduled to provide updates on the Covid 19. These meetings are conducted via skype, zoom and meet me.
5. **Severe Weather Week:** April 20<sup>th</sup> – 24<sup>th</sup>, 2020 is National Severe Weather Week. In years past, the State Wide Tornado Drill has been held on Wednesday of that week. This year, due to the Covid 19 issue, the drill will not be held. I have sent the information that was provided by the NWS to all entities within the county.
6. **Laptop Computer:** I am requesting approval to explore the cost of replacing the current laptop computer that was purchased in 2011. I utilize the computer for skype, zoom and conference calls. Currently, there have been some issues with the computer, but so far, I am able to make the connections for the calls.
7. **Fires & Incidents:**
  - 4/5/2020: Fatality Sig. 1 accident: Highway 18: Oelrichs ambulance, fire, Fall River Sheriff's Office, Hot Springs Ambulance, Fall River Coroner and SD Highway Patrol.
  - 4/6/2020: Grass Fire by Oglala; Oelrichs Fire and Smithwick Fire responded to assist.

*Franklin W. Maynard*  
Franklin W. Maynard, CEM, CFM  
Emergency Manager  
Fall River County  
906 N. River Street  
Hot Springs, SD 57747

FS Agreement No.  
Cooperator Tax ID No.  
Cooperator DUNS No.

07-RO-11020700-039  
476006450  
024980245  
9/27/07

FOREST ROAD AGREEMENT  
BETWEEN THE  
U.S. DEPARTMENT OF AGRICULTURE  
FOREST SERVICE  
NEBRASKA NATIONAL FOREST  
AND  
DAWES COUNTY COMMISSIONERS  
COUNTY OF DAWES

Parties to the Agreement: This agreement, made and entered into this the \_\_\_\_\_ day of \_\_\_\_\_, \_\_\_\_\_, by and between the Forest Service, and the Dawes County Commissioners of Dawes County, State of Nebraska, hereinafter called the “cooperator”. This Agreement supersedes Cooperative Road Agreement No. 66-CA-11020700-011 and all project agreements and modifications thereof.

Purpose of the Agreement: The purpose of this agreement is to set forth the general terms and conditions, acceptable to the parties hereto, for the cooperative planning, survey, design, construction, reconstruction, improvement, and maintenance of certain Forest Development Roads in Dawes County, State of Nebraska, pursuant to the provisions of 16 U.S.C. 532-538, 23 U.S.C. 205, and the regulations issued by the Secretary of Agriculture. This agreement will also provide for the mutual benefit of public interest, and for Forest Service’s purposes of fire suppression, grazing, recreation and various administrative and/or other access uses. Work performed under these areas will be authorized under the Cooperative Funds and Deposits Act of December 12, 1975.

The Congress has, from time to time, authorized and appropriated funds for “Forest Development Roads,” which are defined as “those Forest roads of primary importance for the protection, administration, and utilization of the National Forests, or where necessary, for the use and development of the resources upon which communities within or adjacent to the National Forests are dependent.” Recognizing that substantial benefits will accrue to the Nation and to the State from the construction, reconstruction, improvement, maintenance, and use of certain Forest development roads and roads on the State or local road system over which the cooperator has jurisdiction, and further that such roads carry substantial volumes of public service traffic as well as National Forest traffic, and further that the cooperator has road construction, reconstruction, improvement, maintenance, and right-of-way acquisition facilities available to assist in the accomplishment of the work, it is accordingly deemed fitting and desirable to the parties hereto to express by this instrument the general terms of their mutual cooperation in that regard to achieve the maximum benefits therefrom in the public interest.

1. Intent to Cooperate. It is the intention of the parties under this agreement to cooperate as follows:
  - a. Agree that certain roads under the jurisdiction of the cooperator or the Forest Service that serve the National Forest and also carry traffic that is properly the

FS Agreement No.	07-RO-11020700-039
Cooperator Tax ID No.	476006450
Cooperator DUNS No.	024980245
	9/27/07

responsibility of the cooperator should be maintained and, if necessary, improved to a standard adequate to accommodate safely and economically all traffic that uses such roads.

- b. Agree on the identification of roads or road segments that meet the criteria in item by a listing and appropriate maps.
  - c. Provide for formal meetings and informal consultation on a regular basis to discuss and agree on action with respect to the roads identified pursuant to item b.
  - d. Provide for regular and adequate maintenance of the roads identified in item b, including the assignment of maintenance responsibilities.
  - e. Provide for entering into project agreements when improvements of a road under the jurisdiction of one party is to be financed in whole or in part from funds or resources provided by the other party.
  - f. Provide for appropriate jurisdictional status of roads through transfer of easements and acquisition of easements by the appropriate party.
2. Identification of Roads. A list of roads and segments of roads which meet the criteria set forth in item 1a is agreed upon and is marked "schedule A" and attached as part of this agreement. Schedule A may be modified from time to time by agreement between the cooperator and Forest Service, by adding or removing roads or road segments, or by altering the description of a road or road segments, to give it proper identity. Each such modification shall be indicated by a revised schedule A bearing the signatures of the parties or their authorized representatives and the effective date of the revision.
3. Maintenance Plans. At the annual meeting provided for in item 6, plans for maintaining the roads listed in schedule A shall be agreed upon. Such plans shall include assignment of responsibility for maintenance or particular elements of maintenance to the cooperator or Forest Service for each road or segment of road listed in schedule A. To the extent practical, and subject to availability of funds, responsibility for maintenance shall be assigned in proportion to use for which each party is properly responsible.

Maintenance shall include preserving and keeping the roads, including structures and related facilities as nearly as possible in their original condition as constructed or reconstructed to provide satisfactory and safe road service.

Maintenance plans shall provide for prompt changes in maintenance assignments during the period of the plan upon agreement by the parties or their designated representatives.

FS Agreement No.  
Cooperator Tax ID No.  
Cooperator DUNS No.

07-RO-11020700-039  
476006450  
024980245  
9/27/07

4. Project Agreements. When improvement of a road listed in schedule A is to be financed in whole or in part from funds or resources provided by the party not having jurisdiction, the parties shall enter into a project agreement providing for performing the improvement work and its financing. A project agreement is not required for improvement of a road or a road segment over which the party performing and financing such improvement has jurisdiction. Project agreements shall be supplements to this general agreement and subject to the agreements, provisions, and conditions herein contained.

- a. A project agreement shall be entered into prior to beginning of improvement or construction work for which a project agreement is required.
- b. The project agreement shall include the following elements:
  - 1) Identification of road or road segment to be improved or constructed.
  - 2) Plans and specifications for the project or provision for their development and subsequent agreement thereon.
  - 3) Schedule of construction or improvement work and designation of the party or parties to perform the work.
  - 4) Estimates of cost of improvement or construction.
  - 5) Agreement as to how cost of work is to be borne including arrangements to share in the work or to deposit funds with the performing party for a share of the costs.

c. If funds are provided by the cooperator on an advance basis for work to be performed by the Forest Service, they shall be deposited in the Treasury of the United States to the credit of cooperative work, Forest Service. Any unused balance of cooperative funds for the purposes outlined in the project agreement shall be returned to the cooperator after completion of the work performed or upon agreement of the Forest Service. If the cooperative funds are made available on a reimbursement basis as the work progresses or upon its completion, the Forest Service shall submit to the cooperator periodic billings, but not more often than monthly, or a final billing as the case may be.

The amount of cooperative funds as set forth in the project agreement shall be the maximum commitment of the cooperator to the project unless changed by a modification of the project agreement.

d. If funds are provided by the Forest Service for work to be performed by the cooperator the arrangements shall be set forth in the project agreement.

FS Agreement No.	07-RO-11020700-039
Cooperator Tax ID No.	476006450
Cooperator DUNS No.	024980245
	9/27/07

Payments to the cooperator shall be made as provided for in the project agreement. If it appears that the project cost may exceed the estimate and additional funds may be needed, no obligation shall arise against the Federal government with respect to the increased cost except by modification of the project agreement prior to incurring any commitment.

5. Emergency Situations. During extraordinary situations such as, but not limited to fire emergency or other activities, the Forest Service may request the Cooperator to provide equipment to assist with wildland fire suppression. The Forest Service will reimburse the Cooperator for equipment requested through a project agreement identifying the equipment and the rates of use. Upon execution of both parties the project agreement will become a part of this instrument.
6. Rights-of-Way. Easements or other interests in land acquired by either party shall be adequate to serve the road needs of both parties. The party having jurisdiction of an existing road or intended to have jurisdiction of a road to be constructed shall obtain the needed rights-of-way in its name. There shall be no provisions in any easement document that will prevent the Forest Service from using or authorizing the use of roads for which Federal funds were expended. The cooperator must be in a position to assure the Forest Service the continuance of such uses for the period needed. The party acquiring the easement or other interest in land shall obtain such title evidence and title approval as required in its acquisitions for roads of comparable standards.

The costs of such easements or other interests in land are to be at the expense of the acquiring party.

The Forest Service shall cooperate in the procurement of rights-of-way over land administered by other agencies of the United States required for any project included under this agreement and shall furnish the cooperator copies of survey notes, maps, and other records.

To the extent possible under available authority, each party agrees to convey easements over lands or interests in lands it owns or administers to the other party in order to provide jurisdiction by the appropriate party as may be agreed to for any road or road segment listed on schedule A.

7. Annual Meeting and Continuing Consultation. The cooperator and Forest Service shall meet at least once each year to review matters covered by this agreement and to agree on actions to implement this agreement including, but not limited to, (1) approval of changes in the listing of roads on schedule A; (2) approval of the annual maintenance plan; (3) approval of project agreements for construction or reconstruction; and (4) approval of transfer of jurisdiction of particular roads by easement conveyance. It is also the intent of the parties to

FS Agreement No.	<u>07-RO-11020700-039</u>
Cooperator Tax ID No.	<u>476006450</u>
Cooperator DUNS No.	<u>024980245</u>
	9/27/07

arrange for continuing consultation between their representatives with the objective of reaching prompt agreement by the parties on all matters of mutual concern that are covered by this agreement. The Forest Supervisor or designated representative of the Nebraska National Forest for the Forest Service, and Commissioners or designated representative for the cooperator shall be responsible for making the arrangements for formal meetings and continuing consultation.

8. Modification and Termination.

- a. This agreement may be modified by mutual consent.
- b. This agreement may be terminated by either party upon at least 30 days prior written notice, except that such termination shall in no way affect or change any commitment made authorizing the use of roads or rights-of-way for purposes for which Federal funds were expended, or any operation in progress at time of notice, and provided that such termination shall in no way affect the agreement of the parties hereto with respect to any obligations incurred under the agreement until a full settlement has been made.

9. Miscellaneous

- a. It is understood that any default by a permittee or other authorized road user creates no liability on the part of the Forest Service.
- b. Nothing herein contained shall be constructed to obligate the Forest Service or the cooperator beyond the extent of available funds allocated or programmed for this work, or contrary to applicable laws, rules, and regulations.
- c. No member of, or Delegate to, the Congress, or Resident Commissioner, shall be admitted to any share or part of this agreement or to any benefits that may arise therefrom, unless it is made with a corporation for its general benefit.
- d. Where applicable, any contract, agreement, or understanding entered into pursuant to this agreement providing for work to be performed shall include the requirements of Federal laws, Executive orders, and Regulations.

10. DUNS NUMBER (5/04): The cooperator shall furnish their DUNS number upon execution of this instrument. You may obtain a DUNS number by contacting Dun and Bradstreet at 800-234-3867 or 866-794-1580. A DUNS number will be provided immediately by telephone at no charge.

11. ELECTRONIC FUNDS TRANSFER (EFT) (5/04): The recipient/cooperator shall designate a financial institution or an authorized payment agent through

FS Agreement No.	<u>07-RO-11020700-039</u>
Cooperator Tax ID No.	<u>476006450</u>
Cooperator DUNS No.	<u>024980245</u>
	9/27/07

which a federal payment may be made in accordance with US Treasury Regulations, Money and Finance at 31 CFR 208, which requires that federal payments are to be made by EFT to the maximum extent possible. A waiver may be requested and payments received by check by certifying in writing that one of the following situations apply:

1. The payment recipient does not have an account at a financial institution.
2. EFT creates a financial hardship because direct deposit will cost the payment recipient more than receiving a check.
3. The payment recipient has a physical or mental disability, or a geographic, language, or literacy barrier.

In order to receive EFT payments the recipient/cooperator shall register in the Central Contractor Registry (CCR). You may register by going to [www.ccr.gov](http://www.ccr.gov) and following the instructions provided on line. For assistance, contact the CCR Assistance Center at 888-227-2423 or 269-961-4725

12. **PRINCIPAL CONTACTS.** The principal contacts for this project agreement are:

<p style="text-align: center;"><i>Forest Service Project Contact</i></p> <p>Randy Gage Forest Engineer Nebraska National Forest 125 North Main St. Chadron, NE 69337 Phone: (308) 432-0322 FAX: (308) 432-0309 E-Mail: <a href="mailto:rgage@fs.fed.us">rgage@fs.fed.us</a></p>	<p style="text-align: center;"><i>Cooperator Project Contact</i></p> <p>Russ Finneman Road Foreman District 2, Dawes County 451 Main St. Chadron, NE 69337 Phone: (308) 432-5810 Cell: 430-3423 FAX: (308) 432-5179 E-Mail:</p>
<p style="text-align: center;"><i>Forest Service Administrative Contact</i></p> <p>Timothy Buskirk Agreements Coordinator Trainee USDA Forest Service 125 North Main St. Chadron, NE 69337 Phone: (308) 432-0313 FAX: (308) 432-0309 E-Mail: <a href="mailto:tbuskirk@fs.fed.us">tbuskirk@fs.fed.us</a></p>	<p style="text-align: center;"><i>Cooperator Administrative Contact</i></p> <p>Cheryl Feist County Clerk Dawes County Commissioners 451 Main St. Chadron, NE 69337 Phone: (308) 432-0100 FAX: (308) 432-5179 E-Mail: <a href="mailto:clerk@dawes.nacone.org">clerk@dawes.nacone.org</a></p>

13. **COMMENCEMENT/EXPIRATION DATE.** This instrument is executed as of the date of last signature and is effective through September 30, 2012 at which time it will expire unless extended.

FS Agreement No. 07-RO-11020700-039  
Cooperator Tax ID No. 476006450  
Cooperator DUNS No. 024980245  
9/4/07

14. AUTHORIZED REPRESENTATIVES. By signature below, the cooperator certifies that the individuals listed in this document as representatives of the cooperator are authorized to act in their respective areas for matters related to this agreement.

This agreement shall be effective as of the date herein written and shall supersede all prior existing agreements, if any, for the same roads.

DAWES COUNTY COMMISSIONERS  
COUNTY OF DAWES

USDA FOREST SERVICE  
NEBRASKA NATIONAL FOREST

Gary D. Fischer 25 Sept 07  
GARY D. FISCHER DATE  
County Commissioner

Donald J. Bright 9-26-07  
DONALD J. BRIGHT DATE  
Forest Supervisor

Roger Wess 9-25-07  
ROGER WESS DATE  
County Commissioner

Donald W. Blausey 9-25-07  
DONALD W. BLAUSEY DATE  
County Commissioner

The authority and format of this instrument has been reviewed and approved for signature.

Melody A. Herbert 9/4/07  
MELODY A. HERBERT DATE  
FS Agreements Coordinator

PROJECT AGREEMENT  
between  
DAWES COUNTY BOARD OF COMMISSIONERS  
DAWES COUNTY, NEBRASKA  
AND  
USDA FOREST SERVICE  
NEBRASKA NATIONAL FOREST

THIS PROJECT AGREEMENT, made and entered into by and between the Dawes County Commissioners, Dawes County, Nebraska, hereinafter referred to as the County, and the Forest Service, U.S. Department of Agriculture, hereinafter referred to as the Forest Service under the .

The Forest Service Road Agreement #07-RO-11020700-039, made and entered into by the County and the Forest Service on September 26, 2007 sets forth the responsibilities of each party with respect to the maintenance of Forest Service Road 720 (King's Canyon Road). King's Canyon Road is under a Schedule A agreement with the County.

The purpose of this Project Agreement is for repair work to be performed on ½ mile of the Kings Canyon Road #720. Kings Canyon Road is a county road jointly used by the County and the Forest Service that has historically been maintained by the Forest Service. The single-lane, native surfaced road is maintained for passenger car use and it provides primary access to public lands directly south of Chadron administered by the Nebraska National Forest (Pine Ridge Ranger District). A majority of use on this road is by recreationalists, permittees, contractors, and Forest Service employees accessing the National Forest. During the Winter of 2008/2009 the road surface deteriorated because of excessive moisture in the roadbed resulting in the road being closed. Roadbed rehabilitation and aggregate surfacing are necessary to return the road to a stable condition.

A. The County Shall:

1. Repair the damaged road surface by blading and shaping the existing damaged prism and placing 8" of compacted crushed aggregate surfacing, (approximately 95 tons).
2. Clean and reconstruct ditches on both sides of the road, in an effort to facilitate drainage.
3. Furnish all labor and equipment.

B. The Forest Service Shall:

1. Reimburse the County, not to exceed \$3,000, for the crushed aggregate needed to cap the road, (approximately 95 tons).
2. Supply grass seed for seeding of disturbed areas.

It is Mutually Agreed and Understood by and Between the Said Parties That:

1. This Modification shall be effective upon execution by both parties hereto.
2. AVAILABILITY OF FUNDS. Funds in the amount of \$3,000 are currently available for performance of this instrument through July 31, 2009. The Forest Service's obligation for performance of this instrument beyond this date is contingent upon the availability of appropriated funds from which payment can be made. No legal liability on the part of the Forest Service for any payment may arise for performance under this instrument beyond July 31, 2009 until funds are made available to the Forest Service for performance and until the

recipient/cooperator receives notice of availability to be confirmed in a written modification by the Forest Service.

3. **REIMBURSABLE PAYMENTS.** Reimbursable payments are approved under this instrument. Only costs for those project activities approved in this project agreement are allowable. Requests for payment shall be submitted on Standard Form 270 (SF-270), Request for Advance or Reimbursement, and shall be submitted no more than monthly. Requests for payment shall be submitted to:

USDA Forest Service  
 Albuquerque Service Center  
 Payments-Grants and Agreements  
 101B Sun Ave NE  
 Albuquerque NM 87109  
 Phone: 877-372-7248  
 FAX: 877-687-4894\*

\*FAX invoices to ensure quickest processing

4. **PRINCIPAL CONTACTS.** The principal contacts for this project agreement are:

***Forest Service Project Contact***

Dale Fife  
 Roads Manager  
 Nebraska National Forest  
 125 North Main St.  
 Chadron, NE 69337  
 Phone: (308) 432-0322  
 FAX: (308) 432-0309  
 E-Mail: [dfife@fs.fed.us](mailto:dfife@fs.fed.us)

***Cooperator Project Contact***

Harvey Keim  
 Road Superintendent  
 Dawes County, Nebraska  
 250 Main Street, Suite #7  
 Chadron, NE 69337  
 Phone: (308) 432-0483  
 FAX: (308) 432-5179  
 E-Mail:

***Forest Service Administrative Contact***

Tim Buskirk  
 Agreements Coordinator  
 USDA Forest Service  
 125 North Main St.  
 Chadron, NE 69337  
 Phone: (308) 432-0313  
 FAX: (308) 432-0309  
 E-Mail: [tbuskirk@fs.fed.us](mailto:tbuskirk@fs.fed.us)

***Cooperator Administrative Contact***

Cheryl Feist  
 County Clerk  
 Dawes County Commissioners  
 451 Main St.  
 Chadron, NE 69337  
 Phone: (308) 432-0100  
 FAX: (308) 432-5179  
 E-Mail: [clerk@dawes.nacone.org](mailto:clerk@dawes.nacone.org)

4. **TERMINATION.** Any of the parties, in writing, may terminate the instrument in whole, or in part, at any time before the date of expiration.

No parties shall incur any new obligations for the terminated portion of the instrument after the effective date and shall cancel as many obligations as possible. Full credit shall be allowed for each Party's expenses and all non-cancelable obligations properly incurred up to the effective date of termination.





HOT SPRINGS, SOUTH DAKOTA 57747  
FALL RIVER COUNTY, SOUTH DAKOTA

Name of Claimant: Fall River County Highway Department  
P.O. Box 939  
Hot Springs, S.D. 57747

Date: 04-10-2020
<b>SHERIFF'S DEPARTMENT GAS PURCHASES:</b>
FROM DATE: 03-01-2020
THROUGH DATE: 03-31-2020
<b>TOTAL GALLONS: 983.50</b>
<b>TOTAL: \$ 1947.33</b>

HOT SPRINGS, SOUTH DAKOTA 57747

## FALL RIVER COUNTY, SOUTH DAKOTA

Name of Claimant: Fall River County Highway Department  
P.O. Box 939  
Hot Springs, S.D. 57747

Date: 04-10-2020
<b>COURT HOUSE ...FUEL/GAS PURCHASES :</b>
(All Departments)
FROM DATE: 03-01-2020
THROUGH DATE: 03-31-2020
GALLONS: 99.40
<b>TOTAL: \$ 196.81</b>

FRC HWY: km

HOT SPRINGS, SOUTH DAKOTA 57747

## FALL RIVER COUNTY, SOUTH DAKOTA

Name of Claimant: Fall River County Highway Department  
P.O. Box 939  
Hot Springs, S.D. 57747

Date: 04-10-2020
<b>WEED BOARD FUEL PURCHASES:</b>
<b>FROM DATE: 03-01-2020</b>
<b>THROUGH DATE: 03-31-2020</b>
<b>GALLONS: 85.00</b>
<b>TOTAL: \$ 168.30</b>

FRC HWY: km

TO: Local Government Assistance  
South Dakota Department of Transportation  
700 Broadway Avenue East  
Pierre, South Dakota 57501-2586

RE: LETTING AUTHORIZATION FOR PROJECT NO. BRO 8024(14) PCN 02E8  
IN Fall River COUNTY

This acknowledges that the South Dakota Department of Transportation, Office of Local Government Assistance, estimates the following costs for the noted project:

Preliminary Engineering (State)	\$5,000
Preliminary Engineering (Consultant)	\$341,372
Utilities Relocations	\$ -0-
ROW Acquisitions	\$ -0-
Structure ( <b>LOW BID</b> )	\$1,026,053
Grading ( <b>LOW BID</b> )	\$277,763
Non-participating Costs (Surfacing, Fencing)	\$69,353
Construction Engineering	\$156,458
Estimated Total Project Cost	<u>\$1,876,000</u>

The cost of the project will be covered by 80.00% Federal participation and 20.00% in    State or XX County (check one) matching funds. County matching funds are payable upon billing by the State. Non-participating costs will be paid for by the County.

The South Dakota Department of Transportation is hereby authorized and requested to advertise the project for bids.

The Transportation Commission, under their authority, will review the bids. Approved bids shall be awarded solely by the Transportation Commission.

DATED THIS \_\_\_\_\_ DAY OF \_\_\_\_\_, 20 \_\_\_\_.

BOARD OF COUNTY COMMISSIONERS

OF \_\_\_\_\_ COUNTY

BY: \_\_\_\_\_  
CHAIRMAN

ATTEST: \_\_\_\_\_  
COUNTY AUDITOR  
(SEAL)

Contact Nate Buscher at 773-6649 with any questions.

**FALL RIVER COUNTY RESOLUTION NO. 2020-9**

**AN EMERGENCY RESOLUTION TO ADDRESS A PUBLIC HEALTH CRISIS BY IMPLEMENTING CERTAIN MEASURES WHICH HAVE BEEN DEEMED NECESSARY TO SLOW THE COMMUNITY SPREAD OF CORONAVIRUS (COVID-19).**

WHEREAS, the Fall River County Commission has the authority to pass Resolutions, per SDCL §7-8-20 (10), for the purpose of promoting the health, safety, morals and general welfare, of the community and the promotion of health and the suppression of disease; and

WHEREAS, an outbreak of the disease COVID-19, which is caused by the novel coronavirus, has been confirmed in more than 100 countries, including the United States; and

WHEREAS, COVID-19 is a severe respiratory disease transmitted by person-to-person contact, or by contact with surfaces contaminated by the virus. In some cases, especially among older adults and persons with serious underlying health conditions, COVID-19 can result in serious illness requiring hospitalization, admission to an intensive care unit, and death; and

WHEREAS, the World Health Organization (WHO), the Centers for Disease Control and Prevention (CDC), and the Secretary of the U.S. Department of Health and Human Services have declared the outbreak of COVID-19 as a public health emergency; and

WHEREAS, on March 13, 2020, the President of the United States declared a national emergency in response to the global pandemic of COVID-19; and

WHEREAS, on the same day, Governor Kristi Noem, issued Executive Order 2020-04 which declared a state of emergency to exist in the State of South Dakota in response to the spread of COVID-19; and

WHEREAS, a case of COVID-19 has been confirmed in Western South Dakota; and

WHEREAS, the CDC and health experts have recommended social distancing to slow the spread of COVID-19; and

WHEREAS, social distancing is a method of slowing down or stopping the spread of a contagious disease by reducing the probability of contact between infected persons and those not infected in order to minimize disease transmission; and

WHEREAS, in response to the need to implement social distancing all schools in the state have been closed for at least two weeks; and

WHEREAS, on March 16<sup>th</sup>, 2020, the White House issued guidance recommending that social gatherings of more than ten people be avoided and

WHEREAS, the failure to successfully implement social distancing will likely result in higher numbers of infected individuals and has the potential to overwhelm the capacity of the County's health care providers; and

WHEREAS, it is important that control measures be taken to reduce or slow down the spread of COVID-19 in order to protect the health and safety of the County's residents, especially for seniors and those with underlying health conditions that make them particularly vulnerable to COVID-19.

**NOW THEREFORE, BE IT RESOLVED**, by the Fall River County Commission that:

1. Effective immediately, all Fall River County Facilities are closed to the general public. County and Unified Judicial System offices will continue to operate and conduct business by mail, email, online, by phone or by arranging to work face-to-face/in person on a case-by-case basis.
2. Effective immediately, in cases when a member(s) of the public displays symptoms of COVID-19, as specified by the South Dakota Department of Health, the County offices are directed to refuse face-to-face/in person service and encourage the individual(s) to seek medical attention as specified by public health authorities.
3. This Resolution shall reviewed at each upcoming commission meeting, and appropriate action will be taken as needed.

**BE IT FURTHER RESOLVED**, that this Resolution is necessary for the immediate preservation of the public peace, health, safety, and welfare of Fall River County and shall become effective Monday, March 30<sup>th</sup>, 2020, and is designed to cause the least amount of disruption to the public.

Dated this 27<sup>th</sup> day of March, 2020.

ATTEST:

\_\_\_\_\_  
Joe Falkenburg  
Fall River County Board of Commissioners

\_\_\_\_\_  
Sue Ganje  
Fall River County Auditor

## Governor Noem Teleconferences

4/9/2020

\*SD is seeing more positive cases, 393 as of 4/8/19, 26 have been hospitalized

\*The projected infection rate has been cut in half due to social distancing and staying at home.

\*The Executive Order will remain in place, no groups of more than 10 people, maintain social distancing, stay at home if you aren't working in an essential position.

\*Two Counties, Lincoln and Minnehaha, have a shelter in place order for 21 days, due to high populations of vulnerable people.

\*Gov. Noem tried to give Counties more authority to take action at the local level, the Legislature refused.

\*A Public Health Emergency was proclaimed. This gives the Dept. of Health the ability to take legal action against someone who is positive for COVID19 who won't stay home. Legislature stopped another effort to give Dept. of Health more power.

\*SD is projected to peak with COVID19 infection in June. Restrictions will not begin to be lifted until after the peak.

\*COVID.SD.GOV is the website for current information as well as modeling information for projected cases.

\*No help for property tax replacement from the Federal Govt. for Counties.  
Federal help to individuals and small businesses is outlined on the COVID.SD.GOV website – loan and grant assistance under the community tab.  
Local banks have information on Govt. loans for businesses

\*Mitigation measures may make it take longer for the virus to peak in any area.

\*There are no rules about out of states coming into or SD residents leaving the state at this time. Gov. Noem is not willing to close the State borders as there are too many people who need to travel into and out of the State for work or for essential supplies.

\*Restrooms in State Parks are closed and will remain that way.

4/15/2020

Dusty Johnson also in attendance. Per Dusty Johnson,

\*Congress put wording in the latest aid package that makes it harder for County Governments to get and use the money for their needs. Money is currently to be used for COVID19 specific response expenses only.

\*Nearly every business in SD should be eligible for Payroll Protection loans  
There isn't enough money in the package for all types of Ag production  
There will be some money available from USDA soon

\*SD will receive \$1.25B to be distributed to Counties

Per Gov. Noem

\*Current restrictions such as social distancing and no groups larger than 10 people are working to slow the spread of COVID19. No plans to increase restrictions.

\*The State of SD is open for the trial of the Malaria Drug Hydroxychloroquine

\*Three health systems in SD is on board to gather data on the Malaria drug as it is used, 100,000 people in SD are eligible to be included in the trial

\*COVID.SD.GOV is the website to check daily. Information is added daily.

\*Peak for COVID19 is still projected to be the middle of June for SD

\*App for iPhones is CARE19, if location services is turned on, the app will track your movements and will provide all the information needed if and when you are diagnosed with COVID19, to save time and effort for the State Health Dept. to follow the spread of the disease. This will also help in notifying anyone you came in contact with to help those exposed to self-quarantine. The App should be

available for non iPhones by 4/17/19. Currently SD is one of only two states who are using the App.

\*Smithfield Foods in Sioux Falls is the hot spot for COVID19 in SD. The CDC is currently in the plant. Gov. Noem is pushing to have the plant open in a week. More than 500 positive cases in employees and an additional 100 cases in exposed family members.

\*Not a lot extra capacity at other hog packing plants

\*Some beef cattle sale barns are closing due to low cattle prices. The sale barns plan to reopen, but it is not known when.

\*Families First Act, Counties are not currently covered for reimbursement for the cost of letting employees work from home. Dusty Johnson feels the current aid package money should be able to be used for that as it is a direct cost related to COVID19.

\*The State Health Department will pay for infected people to self-quarantine in a hotel room if they have no way to self-quarantine at home. State Health Department will make daily checks on these people and a Physician will be involved in their care, as well.

\*5,000 extra hospital beds and 3,700 ventilators were made available in SD. At this point in time, fewer than that have been needed.

## EMPLOYEE REQUEST FOR EMERGENCY PAID SICK LEAVE

Employees requesting Emergency Paid Sick Leave (EPSL) pursuant to the Families First Coronavirus Response Act (FFCRA) must complete this form. You must provide as much advance notice as is reasonably practicable. Upon completion of this form, submit it to Human Resources for processing. Submission of the form does not guarantee eligibility or approval for EPSL.

<b>Employee Name:</b>	
<b>Employee Home Address:</b>	
<b>Home Phone Number:</b>	<b>Cell Phone Number:</b>
<b>This is a (choose one):</b> <input type="checkbox"/> New request for leave <input type="checkbox"/> Request for an extension of leave	
<b>Anticipated Begin Date of Leave:</b>	<b>Expected Return to Work Date:</b>
<b>Reason for Leave (check all applicable)</b> I am unable to work (or telework) for the following reasons:	
<input type="checkbox"/> I am subject to a federal, state, or local quarantine or isolation order related to COVID-19; Name of government entity that issued the order: _____	
<input type="checkbox"/> I have been advised by a health care provider to self-quarantine due to concerns related to COVID-19; Name of health care provider and clinic that such advised: _____	
<input type="checkbox"/> I am experiencing symptoms of COVID-19 and am seeking a medical diagnosis; Date medical diagnosis was sought: _____	
<input type="checkbox"/> I am caring for an individual who is subject to quarantine or isolation or advised to self-quarantine by a health care provider due to concerns related to COVID-19; Name of government entity that issued the order: _____ <b>OR</b> Name of health care provider and clinic that such advised: _____	
<input type="checkbox"/> I am caring for a son or daughter whose school or place of care is closed, or childcare provider is unavailable, due to COVID-19; or Name of son or daughter being cared for: _____ Name of child care provider or school that has that has closed or become unavailable: _____	
Explain how no other suitable person will be caring for the son or daughter during the period for which you take Emergency Paid Sick Leave: _____ _____ _____	
<input type="checkbox"/> I am experiencing substantially similar conditions as specified by the Secretary of Health and Human Services, in consultation with the Secretaries of Labor and Treasury.	

**I will need** (choose one):

Continuous leave

Intermittent leave

If your need for leave is intermittent, please describe the nature of your intermittent leave:

---

---

I certify that the above information is accurate and complete. I understand that if I fail to report for work on or before the scheduled return date indicated above or fail to contact Human Resources regarding my absence from work beyond such scheduled date of return, my employer may take corrective action, including termination of employment. I also agree to provide additional information as my Employer may need for tax credits pursuant to FFCRA.

Employee Signature: \_\_\_\_\_ Date: \_\_\_\_\_

Employee Printed Name: \_\_\_\_\_ Date: \_\_\_\_\_

## EMPLOYEE REQUEST FOR EXPANDED FAMILY AND MEDICAL LEAVE

Employees requesting Expanded FMLA (EFMLA) pursuant to the Families First Coronavirus Response Act (FFCRA) must complete this form. You must provide as much advance notice as is reasonably practicable. Upon completion of this form, submit it to Human Resources for processing. Submission of the form does not guarantee eligibility or approval for EFMLA

<b>Employee Name:</b> _____	
<b>Employee Home Address:</b> _____	
<b>Home Phone Number:</b> _____	<b>Cell Phone Number:</b> _____
<b>This is a (choose one):</b> <input type="checkbox"/> New request for leave <input type="checkbox"/> Request for an extension of leave	
<b>Anticipated Begin Date of Leave:</b> _____	<b>Expected Return to Work Date:</b> _____
<b>Reason for Leave (check all applicable)</b> I am unable to work (or telework) because: <input type="checkbox"/> I need to care for my son or daughter under age 18 because my child's elementary or secondary school has been closed due to a public health emergency <input type="checkbox"/> I need to care for my son or daughter under age 18 because my child's place of care has been closed due to a public health emergency. <input type="checkbox"/> I need to care for my son or daughter under age 18 because the child care provider for my son or daughter is unavailable because of a public health emergency.	
<b>Name of son or daughter being cared for:</b> _____	
<b>Name of child care provider or school that has closed or become unavailable due to COVID-19</b> _____	
<b>Explain how no other suitable person will be caring for the son or daughter during the period for which you take Emergency Paid Sick Leave or Expanded FMLA:</b> _____ _____ _____	
<b>I will need (choose one):</b> <input type="checkbox"/> Continuous leave <input type="checkbox"/> Intermittent leave If your need for leave is intermittent, please describe the nature of your intermittent leave: _____ _____ _____	
<b>Substitution of Paid Leave:</b> Pursuant to the FFCRA, the first 10 days of your leave is unpaid, however you may be eligible for emergency sick leave provided through the FFCRA. In the event you are not eligible for emergency sick leave, you are permitted to use available paid leave to cover this period. Please indicate if you would like to use paid leave during the first 10 days of your absence (if you are not eligible for emergency sick leave) and how many hours you plan to use. <input type="checkbox"/> Vacation (____ Hrs) <input type="checkbox"/> Sick Leave (____ Hrs)	

I certify that the above information is accurate and complete. I understand that if I fail to report for work on or before the scheduled return date indicated above or fail to contact Human Resources regarding my absence from work beyond such scheduled date of return, my employer may take corrective action, including termination of employment. I also agree to provide additional information as my Employer may need for tax credits pursuant to FFCRA.

Employee Signature: \_\_\_\_\_ Date: \_\_\_\_\_

Employee Printed Name: \_\_\_\_\_ Date: \_\_\_\_\_

## COVID-19 Confirmed Positive, Exposure & Potential Exposure

### Action Steps

**A. Employee Confirmed Positive.** If an employee has tested positive for COVID-19:

- 1) The employee should not report to work and should already be on a 14-day quarantine period as recommended by the Center for Disease Control (CDC) starting at least by when the test was administered. The employee should further isolate if possible.
  - a. While quarantined or isolated, the employee may be allowed to work remotely if s/he is able to do so. If the employee is unable to work remotely, the employee may be able to use Emergency Paid Sick Leave (EPSL) or Sick Leave (SL) if the employee qualifies/it is available.
- 2) The employer should immediately contact the Facilities Department to thoroughly sanitize the employee's work area and any work surfaces with which the employee knowingly came in contact pursuant to the guidelines provided by the CDC.
- 3) The employer should ask the employee to identify clients, vendors, colleagues, business contacts, or other individuals who were in close contact with him/her during the ten days prior to receiving a positive test result.
- 4) The employer may inform the Department of Health\*. The Department of Health may also contact the employee to inquire about close contact with others. The Department of Health may also contact the employer to inform them of staff who may have been in close contact with the individual who tested positive.
- 5) The employer should communicate with all employees regarding potential exposure in the workplace and share the measures and steps being taken to ensure employee health and safety. The employers should remind employees of options available to them to minimize their risk of exposure, including alternative work options and teleworking. The name of the employee who tested positive must not be shared or disclosed in any form or fashion.
- 6) If an employee tested positive and no re-test is being conducted, the employee may return to work when: (i) The employee has no fever for at least 72 hours (three (3) full days of no fever (100.4F) and without the use of fever-reducing medication) **AND**; (ii) The employee has noticeable improvement in respiratory symptoms (for example, when cough or shortness of breath have improved); **AND** (iii) At least seven (7) days have passed since symptoms first appeared.

**B. Employee's Family Member/Roommate Confirmed Positive.** If an employee's immediate family member with whom the employee is living, or employee's roommate has tested positive for COVID-19 and that person has not self-isolated from the employee\*\* :

- 1) The employee should not report to work and will be placed on a 14-day quarantine period as recommended by the CDC and the employee should monitor for symptoms including taking

temperatures twice daily. While on quarantine, the employee may be allowed to work remotely if s/he is able to do so. If the employee is unable to work remotely, EPSL or SL may be a possibility.

- a. This is true unless the employee is an Emergency Responder/Health Care Worker who cannot work remotely, and a determination is made not to place the employee on quarantine unless they become symptomatic; if so then the employer should prescreen the employee for symptoms prior to work and routinely disinfect common areas, and the employee shall monitor for symptoms including taking temperatures twice daily and shall report any symptoms to the supervisor, shall wear a facemask at work for 14 days after the date of the last exposure, and shall engage in social distancing practices.
- 2) The employer should immediately contact the Facilities Department to thoroughly sanitize the employee's work area and any work surfaces with which the employee knowingly came in contact pursuant to the guidelines provided by the CDC.
  - 3) Contact employees within the department of the individual who may have been exposed to let them know that there may be *potential* exposure and they should self-monitor for symptoms. Also, let department employees know that they will be advised as soon as results are received to confirm whether there was actual exposure. The name of the employee who tested positive must not be shared or disclosed in any form or fashion.
  - 4) If the employee is tested and the results are negative:
    - a. Allow the employee to return to work (prior to the expiration of the 14-day quarantine period) and have the employee continue to self-monitor for symptoms. The employee should report to the Supervisor if they are experiencing any symptoms prior to coming to work and may instead be placed on a 14-day quarantine period.
    - b. Contact department employees and inform them that there was no actual exposure.
  - 5) If results are positive, refer to Action Steps (A)(3-6) above.

**C. Coworker or Resident/Inmate Confirmed Positive and Employee has had Close Contact Exposure:** If an employee has been exposed (through close contact as defined by CDC) to a coworker, resident or inmate who has tested positive for COVID-19, then steps (B)(1-5) should be followed.

**D. Employee has had Close Contact to a Coworker or Resident/Inmate who has been Exposed to Someone who has Confirmed Positive:** Employee should monitor symptoms including taking a temperature twice daily and report any symptoms to a supervisor.

**E. Employee has Symptoms of a fever or shortness of breath, but has not been Exposed to Someone who Tested Positive:** Employee should stay home from work and social distance until 72 hours after the fever is gone or symptoms are better. Use of EPSL or SL may be a possibility.

\*The employer is not responsible for contacting any government agency, the Department of Health or the CDC with an employee's positive test result. The healthcare provider is required to report positive test results to these agencies.

\*\*Isolation involving a roommate/family member means the employee is using a separate bathroom or bedroom from the roommate/family member and is not providing direct care for that person.

\*\*\*Updates from the CDC and/or DOH may cause modifications to this policy with or without notice to employees.

## **Families First Coronavirus Response Act (FFCRA) Procedure**

It is the procedure of \_\_\_\_\_ (list entity) to comply with the requirements of the Federal Families First Coronavirus Response Act (FFCRA), unless we otherwise deem you to be an emergency responder/health care worker. The FFCRA provides eligible employees with Emergency Paid Sick Leave and Expanded Family and Medical Leave (EFMLA) for those affected by the COVID-19 pandemic, from April 1, 2020 through December 31, 2020.

### **Two Types of Leave Covered Under FFCRA**

#### **1) Emergency Paid Sick Leave (EPSL)**

Emergency paid sick leave will be available for an employee who is unable to work or work remotely because:

1. The employee is subject to a federal, state, or local quarantine or isolation order related to COVID-19;
2. The employee has been advised by a health care provider to self-quarantine due to concerns related to COVID-19;
3. The employee is experiencing symptoms of COVID-19 and is seeking a medical diagnosis;
4. The employee is caring for an individual who is subject to quarantine or isolation or advised to self-quarantine by a health care provider due to concerns related to COVID-19;
5. The employee is caring for a son or daughter whose school or place of care is closed, or childcare provider is unavailable, due to COVID-19 precautions; or
6. The employee is experiencing substantially similar conditions as specified by the Secretary of Health and Human Services, in consultation with the Secretaries of Labor and Treasury.

#### **Eligibility for EPSL**

All employees, regardless of their tenure with the organization, with full-time or part-time status are eligible to receive this benefit.

#### **Paid Benefits for EPSL**

Eligible employees will receive up to two weeks of paid sick leave.

- Full-time employees (scheduled to work 40 or more hours per week): 80 hours at their regular rate of pay, subject to caps and reasons noted below.
- Part-time employees (scheduled to work less than 40 hours per week): the number of hours that the employee works, on average, over a two week period, subject to caps and reasons noted below.

Payments are capped at \$511 a day (\$5,110 in total) for dealing with an employee's own illness or quarantine (reasons 1, 2 and 3 above). Employees who are caring for an individual affected by COVID-19 and those whose children's schools or childcare providers have closed (reasons 4, 5 and 6 above) receive up to two-thirds of their pay, and that benefit is limited to \$200 a day (\$2,000 in total).

## **Return to Work Following EPSL**

Employees are required to follow guidelines established by the Centers for Disease Control and Prevention as it relates to ceasing home isolation practices. Please notify your supervisor when you are able to return to work.

## **2) Expanded Family Medical Leave Act (EFMLA) Expansion**

Employees may be entitled to take up to 12 weeks of job-protected leave if an employee is unable to work (or remote work) due to caring for the employee's son or daughter because the child's school or place of care has been closed or his or her childcare provider is unavailable due to the public health emergency. Prior use of FMLA leave in the rolling 12 month period reduces EFMLA leave by the amount used to date.

### **Eligibility for EFMLA**

Under this policy, full-time and part-time employees who have been on \_\_\_\_\_ (list the entity) payroll for 30 days, prior to taking the leave, are eligible for leave.

### **Paid Benefits for EFMLA**

The EFMLA provides for a combination of unpaid and paid leave.

- The first 10 days of EFMLA may be unpaid. An employee may choose to take any existing pay benefit (i.e. PTO, vacation, sick pay) during the 10-day unpaid period, or the 10 days may be paid under emergency paid sick leave (if not already used), if taken for a qualifying reason.
- After ten days of unpaid leave, employees are entitled to 10 weeks of job-protected leave of two-thirds their usual pay. Part-time employees are entitled to be paid two-thirds of their usual pay based on the average number of hours worked for the six months prior to taking the leave.
- The cap of the paid leave entitlement for employees is \$200 per day (\$10,000 in the aggregate).

### **Notifying Company of the Need for FFCRA Leave**

Employees should request their need for emergency paid leave as soon as possible, by notifying their immediate supervisor or human resources and filling out a request form indicating the specific qualifying reason and date of requested leave. If an employee is incapacitated, the employee's representative should give verbal notice as soon as possible. Calling in "sick" does not qualify as adequate notice. An employee must provide sufficient information regarding the reason for an absence for the company to know that protection and benefits may exist under this policy.

### **Insurance Benefit Continuation During FFCRA Leave**

Coverage under group health insurance will continue while on leave, but employees must continue to pay their portion of the premium. Other employment benefits [*such as group life insurance, AD&D, etc.*] will also be continued during the leave, as long as the employee continues to pay any required contribution. Payment arrangements will be discussed with individuals upon their request for leave.

## **Documentation for FFCRA Leave**

To take EPSL or EFMLA leave, the employee needs to provide documentation containing the following information:

1. Employee's name;
2. Date(s) for which leave is requested;
3. Qualifying reason for the leave; and
4. Oral or written statement that the Employee is unable to work because of the qualified reason for leave.
5. As to EPSL for a qualifying COVID-19 related reason as above listed, also provide:
  - For reason #1: The name of the government entity that issued the Quarantine or Isolation Order;
  - For reason #2: The name of the health care provider who advised the Employee to self-quarantine due to concerns related to COVID-19;
  - For reason #3: The name of the government entity that issued the Quarantine or Isolation Order to which the individual being cared for is subject; or the name of the health care provider who advised the individual being cared for to self-quarantine due to concerns related to COVID-19.
  - For reason #5: The name of the Son or Daughter being cared for; the name of the School, Place of Care, or Child Care Provider that has closed or become unavailable; and a representation that no other suitable person will be caring for the Son or Daughter during the period for which the Employee takes Paid Sick Leave or Expanded Family and Medical Leave.

Additional documentation may also be required related to the tax credit.

Providing false information will be seriously treated and discipline including termination may occur.

## **Intermittent Leave**

For employees working on the premises, intermittent leave will only be permitted for the qualifying reason related to caring for their minor child whose school or place of care is closed, or childcare provider is unavailable. For employees working remotely, intermittent leave will be permitted if the employee is unable to work his or her normal schedule of hours.

The employee and employer will come to an agreement on a schedule that provides for the least amount of disruption to an employee's job. For EFLMA purposes, the total amount of leave taken in should not exceed the 12 weeks defined earlier in this policy.

## **Rights Upon Return from FFCRA Leave**

An employee who takes leave under this policy may be reinstated to the same job or an equivalent position upon completion of the leave. If an individual has exhausted all leave under this policy and is still unable to return to work, the situation will be reviewed on a case-by-case basis to determine what rights and protections might exist.

The law provides that an employee has no greater rights upon a return from leave than the individual would have had if s/he had continued to work. Therefore, an employee may be affected by a layoff, reorganization, furlough, change in job duties or other change in employment if the action would have occurred had the employee remained actively at work.

## Telecommuting Agreement for COVID-19

Employee Name: \_\_\_\_\_

Company's Department/Division: \_\_\_\_\_

Telecommuting Location: \_\_\_\_\_

This agreement establishes the terms and conditions of telecommuting on a temporary basis. Company reserves the right to terminate telecommuting at its discretion. Telecommuting is defined as working at home or at other off-site locations that are linked electronically to a central office.

- 1. Work Hours:** Hours worked, overtime compensation, compensatory time, and leave benefits will not change as a result of telecommuting. (or add: Any changes to normal work hours must be approved in advanced by Employee's supervisor).
- 2. Work Area:** The employee agrees to designate a separate work space for the purpose of telecommuting and will maintain the area in a safe condition, free from hazards and other dangers to the employee and the Company's equipment.
- 3. Equipment:** Equipment listed below will be provided and maintained by the Company. The employee must protect the equipment from damage and unauthorized use. The equipment, software, data, supplies and furniture is limited to use by authorized persons only and for the purposes relating to Company business.
- 4. Costs:** The Company will not be responsible for operating costs, home maintenance, or any other incidental costs (i.e. utilities), associated with the use of the employee's residence.
- 5. Liability:** The Company will not be liable for damages to the employee's property resulting from telecommuting, and the employee agrees to hold the Company harmless against any and all claims, excluding worker's compensation claims.
- 6. Worker's Compensation:** The employee is covered by worker's compensation if injured in the course of performing official duties at the telecommuting location in the designated work area.
- 7. Work Assignments:** The employee will continue to receive work assignments from leadership. The employee must be able to be present at his/her office/department as necessary to attend meetings, training sessions, or similar events or occurrences.
- 8. Records and Company information:** The employee will apply safeguards to protect records/files from unauthorized disclosure or damage. Any company materials kept in the home should be kept in the designated work area at home and not made accessible to others. The employee will take all necessary steps to protect the integrity and confidentiality of the Company's systems, such as protecting passwords and prohibiting unauthorized individuals from viewing Company files. All electronic work files should always be saved and stored on the central office network.

9. **Communication:** The employee must be available by phone and email during work hours.

10. **Domestic Care:** The employee agrees that family care demands shall not compete with the work hours established between the employee and the supervisor except in the case of an emergency. Remote work will not be a substitute for child care, elder care, or other dependent care. Similarly, pets and other distractions may not impede the employee's ability to effectively perform job duties.

11. **Policies:** The employee is required to comply with the Company's executive orders, policies, rules, practices and instructions.

I agree to abide by the terms and conditions of this agreement.

Employee Signature: \_\_\_\_\_ Date: \_\_\_\_\_

Approved by Director or Designee: \_\_\_\_\_ Date: \_\_\_\_\_

Company Equipment	Make	Model	Computer #	Notes
Computer				
Company Phone				
_____				
_____				

Company Directors or Designees must email a PDF copy of this signed agreement to \_\_\_\_\_.

Possible Add in:

**Internet Access:** Internet accessibility is necessary for telecommuters to perform their job responsibilities. High speed internet access with a minimum service requirement of DSL or Cable Modem is required.